

HVAC Copper/Metal Theft Prevention



Field-Proven, Simple and Effective Copper Theft Deterrence

Copper Cop™ is an efficient, dependable and reliable security protection solution designed to combat theft of commercial air conditioning (HVAC) units. Copper Cop can be installed and activated in minutes by a security professional and, unlike other HVAC alarm products, does not require an HVAC, Plumber's or Electrical Contractor's License.

Thousands of commercial HVAC units are destroyed each year by thieves seeking to gain quick cash by stealing copper condenser lines and selling them at scrap yards. The cost of business disruption can be high, including replacement of the HVAC system, and inability to use the facility while the HVAC service is being restored. Additionally, repeated thefts increase a company's insurance premiums, making copper theft one of the most vexing challenges businesses face today.

Linear, a leader in innovative and cost-effective security products and theft prevention systems, has developed Copper Cop for Security dealers and integrators whose customers want a quick, secure, and active deterrence solution.

The Solution Is Here

Linear's Copper Cop consists of a unique 30-foot cable harness with eight self-tapping screw-in clip assemblies, connected to a weatherproof alarm interconnect box. The system is ready to accept a wireless alarm transmitter or hard-wired connection to a security alarm panel. Once Copper Cop is installed on the exterior of the HVAC unit and activated, removal of the HVAC unit cover or tampering with the cable triggers an alarm.



Copper Cop tamper-resistant alarm interconnect box



Copper Cop cable harness & interconnect box



HVAC Copper/Metal Theft Prevention

Features

- Reliable, simple non-intrusive solution to guard against HVAC unit copper or metal theft
- Does not require Electrician's, Plumber's or HVAC Contractor's license
- Does not trigger a false alarm even if fluctuations in refrigerant pressure or electrical power outages occur*
*Connected alarm system must have backup battery power to operate properly during a power outage
- Ready to accept hard-wired alarm system connection or wireless alarm transmitter
- Optional secondary 30-foot harness can be added to cover larger commercial HVAC units (60' length total)
- Bright yellow cable harness acts as a visual deterrent to would-be thieves

Target Markets

- Schools
- Single-Story Retail Buildings
- Remote Communication Centers
- Places of Worship
- Cellular Network Facilities / Towers
- Substation Outbuildings

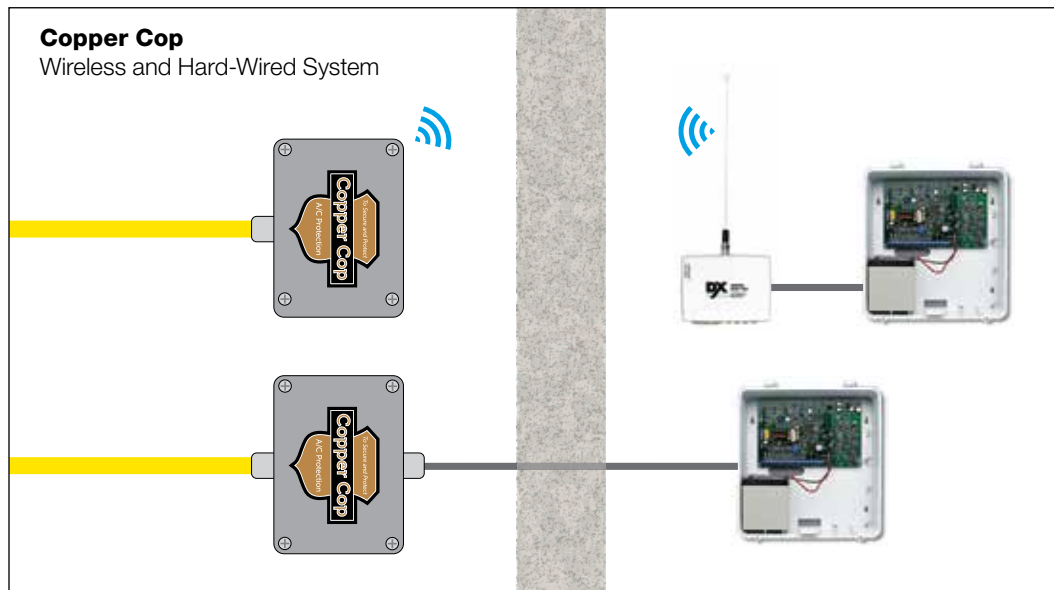

Accessories

Model #	Description
DXS-31	Wireless RF Alarm Sensor Transmitter
DXR-702	2-Channel Wireless RF Alarm Sensor Receiver
CC3008XT	Secondary 30-foot Extension Harness (for larger HVAC units)
CC3008WK1	Copper Cop Kit with Wireless Transmitter and Receiver

For more information, please visit www.linearcorp.com.
Specifications subject to change without notice.

