

# LRA

## Linear Residential Actuator Installation Guide

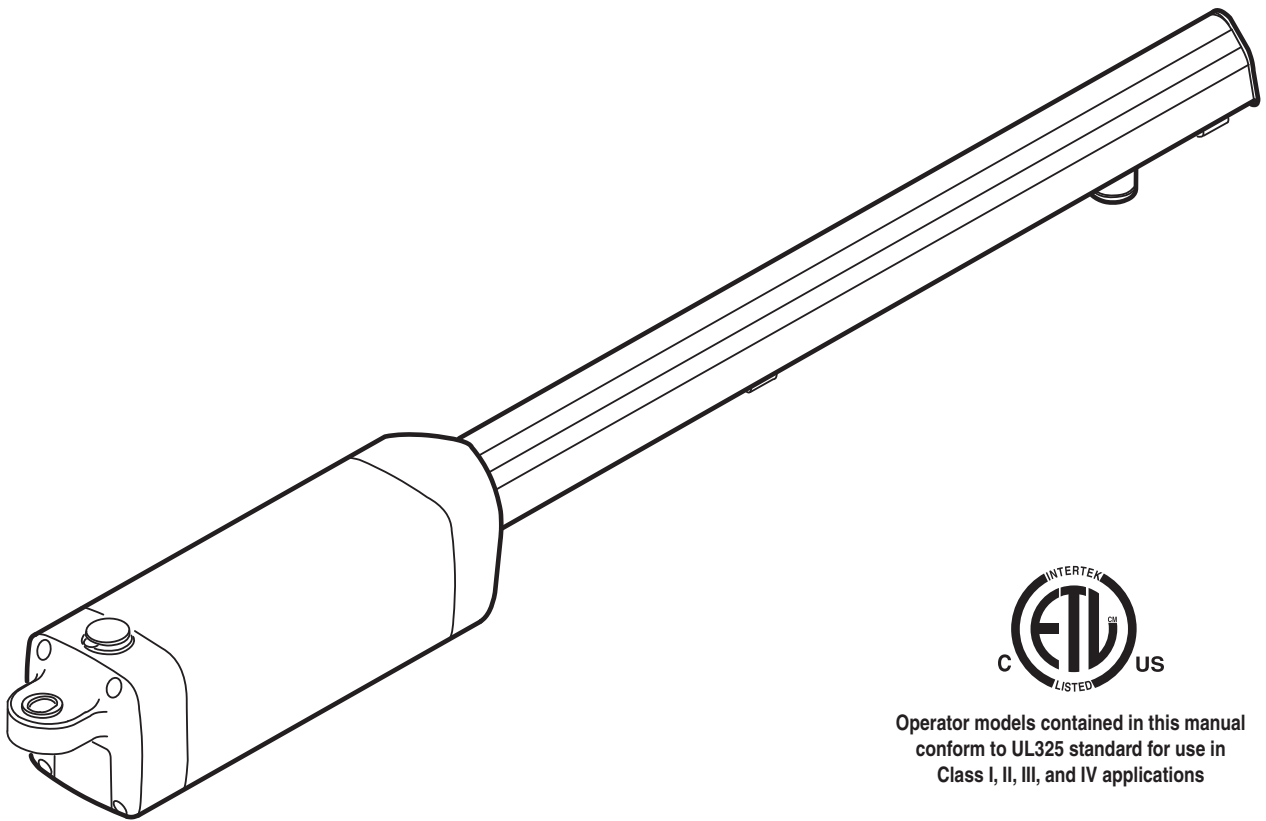

Operator models contained in this manual  
conform to UL325 standard for use in  
Class I, II, III, and IV applications

**Linear**<sup>®</sup>  
*Building On Innovation.*

USA & Canada (800) 421-1587 & (800) 392-0123  
(760) 438-7000 - Toll Free FAX (800) 468-1340  
[www.linearcorp.com](http://www.linearcorp.com)

# Table of Contents

<b>Pre-installation Information</b> . . . . .	1
Before You Begin . . . . .	1
Always Check the Gate's Action . . . . .	1
Gate Operator Classifications . . . . .	1
Approved Obstruction Detection Devices . . . . .	1
<b>Safety Information and Warnings</b> . . . . .	1
Regulatory Warnings . . . . .	1
<b>Linear Actuator Operator Overview</b> . . . . .	2
<b>Wiring Specifications</b> . . . . .	2
AC Power Wiring . . . . .	2
DC Control and Accessory Wiring . . . . .	2
<b>Control Box Mounting</b> . . . . .	2
<b>Gate Layout Illustration</b> . . . . .	3
<b>Mounting Bracket Installation</b> . . . . .	4
Universal Post Bracket Installation . . . . .	4
Gate Bracket Installation . . . . .	4
<b>Operator Setup</b> . . . . .	5
Operator Mounting . . . . .	5
Controller Connection . . . . .	5
AC Power Connection . . . . .	6
Earth Ground . . . . .	6
Manual Disconnect . . . . .	6
Dual Gate Stagger Delay . . . . .	6
Limit Switch Adjustment . . . . .	8
<b>Controller Features</b> . . . . .	9
<b>Indicator Descriptions</b> . . . . .	10
<b>Terminal Descriptions</b> . . . . .	11
<b>Operator Accessory Connections</b> . . . . .	12
<b>Basic Controller Programming</b> . . . . .	13
Programming Overview . . . . .	13
Entering Programming Mode . . . . .	13
Exiting Programming Mode . . . . .	13
Programming Keystrokes . . . . .	13
Left or Right Hand Operation . . . . .	13
Dual Gate Enable . . . . .	13
Auto Close Timer . . . . .	13
Run Alarm and Pre-start Alarm . . . . .	14
Maximum Open Direction Current Setting . . . . .	14
Maximum Close Direction Current Setting . . . . .	14

<b>Advanced Controller Programming</b> . . . . .	15
Entering Advanced Programming Mode . . . . .	15
Maximum Run Time . . . . .	15
Single Button Input Setup . . . . .	15
Auxiliary Relay Mode . . . . .	16
Reverse Delay Time . . . . .	16
Constant Pressure Mode . . . . .	16
Shadow Loop Open Prevention . . . . .	16
Low Power Mode . . . . .	17
Power Failure Mode . . . . .	17
Soft Start/Stop Duration . . . . .	17
Reset Cycle Count . . . . .	17
Maintenance Alert Trigger . . . . .	18
Mid-travel Stop Position . . . . .	18
Anti-tailgate Enable . . . . .	18
Motor Type Selection . . . . .	18
Radio Enable . . . . .	19
Antenna Installation . . . . .	19
Radio Transmitter Learn . . . . .	19
Radio Transmitter Delete . . . . .	19
MGT Obstacle Transmitter Learn . . . . .	19
MGT Obstacle Transmitter Delete . . . . .	19
Reset Controller to Factory Defaults . . . . .	19
<b>Loop Layout Illustration</b> . . . . .	20
<b>Safety Edge Layout Illustration</b> . . . . .	21
<b>Photoeye Installation Illustration</b> . . . . .	22
<b>Gate Operation</b> . . . . .	23
Open Button . . . . .	23
Close Button . . . . .	23
Stop Button . . . . .	23
Single Input . . . . .	23
Fire Department Input . . . . .	23
Open Input . . . . .	23
Open Obstruction . . . . .	23
Close Obstruction . . . . .	23
Reverse Input . . . . .	23
Open Loop . . . . .	23
Reverse Loop . . . . .	23
Shadow/Reset Loop . . . . .	23
<b>Operation Indications</b> . . . . .	23
Power-up Display . . . . .	23
Idle Condition . . . . .	23
Last Gate Position/Condition . . . . .	23
Pre-start Delay . . . . .	23
Reverse Delay . . . . .	23
Run Timer . . . . .	23
<b>Error Indications</b> . . . . .	24
Entrapment . . . . .	24
MGT Obstacle Transmitter Trouble . . . . .	24
Maximum Run Time Exceeded . . . . .	24
<b>Troubleshooting</b> . . . . .	25
Contacting Technical Support . . . . .	25
Operator fails to start . . . . .	25
Motor operates, but gate does not move . . . . .	25
Motor sounds like it is working harder than normal . . . . .	25
Gate stopping part way open or closed (but no visible obstruction) . . . . .	25
Gate staying open with automatic system . . . . .	25
How to Order Replacement Parts . . . . .	25
<b>Model LRA Replacement Parts</b> . . . . .	26
<b>Preventative Maintenance</b> . . . . .	27
General . . . . .	27
Lubrication . . . . .	27
6-Month Preventative Maintenance . . . . .	27
Battery Maintenance . . . . .	27
<b>FCC Notice</b> . . . . .	27
<b>Gate Operator Installation Checklist</b> . . . . .	28

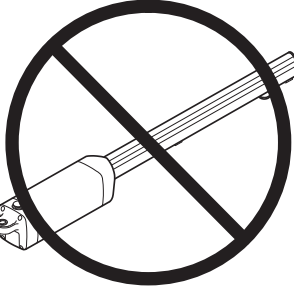

**WARNING**

ONLY QUALIFIED TECHNICIANS SHOULD WORK ON LINEAR RESIDENTIAL ACTUATORS



---



**WARNING**



CONTROLS INTENDED FOR USER ACTIVATION MUST BE LOCATED AT LEAST SIX FEET (6') AWAY FROM ANY MOVING PART OF THE GATE AND WHERE THE USER IS PREVENTED FROM REACHING OVER, UNDER, AROUND OR THROUGH THE GATE TO OPERATE THE CONTROLS. OUTDOOR OR EASILY ACCESSIBLE CONTROLS SHALL HAVE A SECURITY FEATURE TO PREVENT UNAUTHORIZED USE.

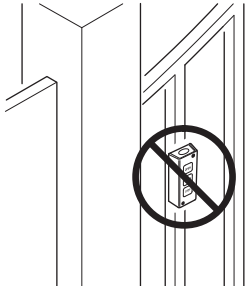

## Pre-installation Information

### Before You Begin...

Before unpacking, inspect the carton for exterior damage. If you find damage, advise the delivery carrier of a potential claim. Inspect your package carefully. You can check your accessory box parts with the enclosed packing slip for your convenience. Claims for shortages will be honored for only 30 days from the date of shipment.

Before installing the operator, read this manual completely to ensure all requirements for proper installation are present. Verify that the voltage to be used matches the voltage of the operator.

If you have any questions about the requirements for proper installation of this gate operator contact technical support at 800-421-1587.

### Always Check the Gate's Action

It's very important before installing the gate operator to make sure the gate's swing is free and level throughout the entire swing path. If the gate does not seem to operate properly, it may affect the operator performance or greatly shorten the life of the unit. The gate should also be designed so that airflow is ample to prevent wind resistance and drag.

### Gate Operator Classifications

All gate operators can be divided into one of four different classifications, depending on their design and usage. Install this gate operator only when the operator is appropriate for the construction and usage class as defined below:

- **Class I Residential Vehicular Gate Operator**  
A vehicular gate operator intended for use in a home or for one to four single family dwellings with a common garage or parking area associated with these dwellings.
- **Class II Commercial / General Access Vehicular Gate Operator**  
A vehicular gate operator intended for use in a commercial location or building such as a multi-family housing unit of five or more single family units, hotel, retail store or other building servicing the general public.
- **Class III Industrial / Limited Access Vehicular Gate Operator**  
A vehicular gate operator intended for use in an industrial location or building such as a factory or loading dock area or other location not intended to service the general public.
- **Class IV Restricted Access Vehicular Gate Operator**  
A vehicular gate operator intended for use in a guarded industrial location or building such as an airport security area or other restricted access locations not servicing the general public, in which unauthorized access is prevented via supervision by security personnel.

### Approved Obstruction Detection Devices

The following contact or non-contact obstruction detection devices have been approved for use with Linear's Residential Actuators as part of a UL325 compliant installation:

- **Contact Edges**  
Miller Edge Models MGO20, MGR20, MGS20, ME120
- **Photoeyes**  
MMTC Model IR-55 (165' range - P/N 2520-441)  
MMTC Model E3K (28' range - P/N 2520-031)

## Safety Information and Warnings

THE FOLLOWING FORMATS ARE USED FOR SAFETY NOTES IN THESE INSTRUCTIONS.



### Regulatory Warnings

Read the following before beginning to install Linear's Residential Actuators:

**IMPORTANT INSTALLATION SAFETY INSTRUCTIONS**

**WARNING**

**TO REDUCE THE RISK OF SEVERE INJURY OR DEATH TO PERSONS, REVIEW THESE INSTALLATION SAFETY STEPS BEFORE PROCEEDING**

1. READ AND FOLLOW ALL INSTALLATION INSTRUCTIONS.
2. Read the yellow "Safety Instructions" brochure enclosed with the packet of information. If any pages are missing or are unreadable, or you do not have the safety instructions, please call Linear at 1-800-421-1587 to request additional copies.
3. ALL ELECTRICAL CONNECTIONS TO THE POWER SUPPLY MUST BE MADE BY A LICENSED ELECTRICIAN AND MUST OBSERVE ALL NATIONAL AND LOCAL ELECTRICAL CODES.
4. A separate power-disconnect switch should be located near the operator so that primary power can be turned off when necessary.
5. Install the enclosed warning signs on both sides of the gate. A minimum of two (2) WARNING SIGNS shall be installed, one on each side of the gate where easily visible.
6. Never reach between, through or around the fence to operate the gate.
7. Never connect a button station within reach of the gate or on the side of the gate operator.
8. Do not adjust the operator controller's current sensing feature too high. It should be adjusted high enough to keep the gate from falsely triggering the sensing, but no higher than necessary for the gate to operate. **DO NOT DEFEAT THE PURPOSE OF THIS FUNCTION!**
9. You must install all required safety equipment.
10. UL325 Compliance requires the use of contact edges or photoelectric controls on all automatic or remotely-controlled gate operators.
11. The operator is intended for installation only on gates used for vehicles. Pedestrians must be supplied with a separate access opening. The pedestrian access opening shall be designed to promote pedestrian usage. Locate the gate such that persons will not come into contact with the vehicular gate during the entire path of travel of the vehicular gate.

## Linear Actuator Operator Overview

The Model LRA Residential Linear Actuator is designed to open and close a light-duty residential swing gate. The operator can be used in left-hand or right-hand swing gate installations on gate(s) with leaves weighing up to 600 pounds.

The LRA operator (or two LRA operators in dual gate installations) connect by a cable to the APeX electronic controller, which provides all connections for input and entrapment detection devices. The Controller is housed in a separate enclosure and contains a built-in radio receiver for wireless activation by remote control transmitters.

Brackets attached to the gate and gate hinge post are for mounting the operator and to provide a mechanism to move the gate.

When the operator activates, the worm drive in the linear actuator changes the fixed distance between the two brackets that the operator is mounted on. When the operator pulls the two brackets closer together, the gate opens. When the operator pushes the two brackets farther apart, the gate closes (see Figure 1).

Adjustable magnetic limit switches in the operator detect the open and closed positions of the gate.

**⚠ WARNING ⚠**

**This operator is intended for installation only on gates used for vehicles. Pedestrians must be supplied with a separate access opening. The pedestrian access opening shall be designed to promote pedestrian usage. Locate the gate such that persons will not come into contact with the vehicular gate during the entire path of travel of the vehicular gate.**

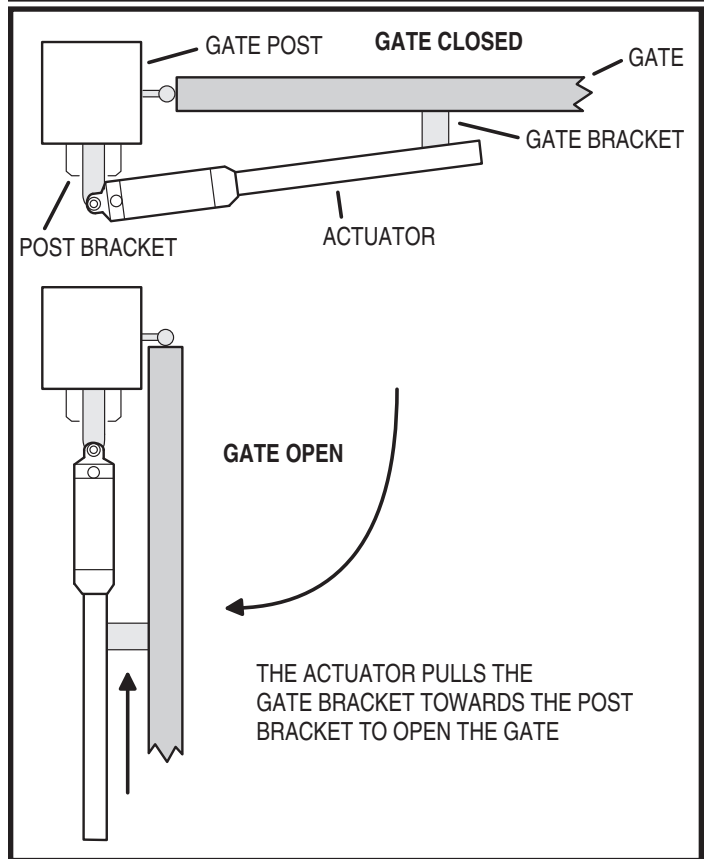

Figure 1. Linear Actuator Operation

## Wiring Specifications

Refer to the following steps for details on power and accessory wiring for the operator.

**⚡ WARNING ⚡**

**ALL AC ELECTRICAL CONNECTIONS TO THE POWER SOURCE AND THE OPERATOR MUST BE MADE BY A LICENSED ELECTRICIAN AND MUST OBSERVE ALL NATIONAL AND LOCAL ELECTRICAL CODES**

### USE COPPER WIRE ONLY!

### AC Power Wiring

SUPPLY VOLTS	MODEL LRA POWER WIRING MAXIMUM DISTANCE (FEET)		WIRE GAUGE
	SINGLE	DUAL	
115 VOLTS	3288	1644	14
	5224	2612	12

1. The distance shown in the table above is measured in feet from the operator to the power source. **DO NOT EXCEED THE MAXIMUM DISTANCE.** These calculations have been based on a standard 115 V supply with a 10% drop allowable. If your supply is under the standard rating, the runs listed may be longer than what your application will handle, and you should not run wire too near the maximum distance for the gauge of wire you are using.
2. When large-gauge wire is used, a separate junction box (not supplied) may be needed for the operator power connection.
3. Wire length calculations are based on the National Electrical Code, Article 430 and have been carefully determined based on motor inrush and operator requirements.
4. Connect power in accordance with local codes. **The green ground wire must be properly connected.**
5. Wire insulation must be suitable to the application.

### DC Control and Accessory Wiring

1. **All control devices are now 24 VDC, which can be run up to 2000 feet with 14 AWG wire.**
2. Control wiring must be run in a separate conduit from power wiring. Running them together may cause interference and faulty signals in some accessories.

### Control Box Mounting

Locate the control box in the vicinity of the operator. The APeX Controller mounts inside the control box. The operator connects to the Controller via a 6-foot cable. For dual gate installations, the LRA2 kit includes a 40-foot cable for the second operator.

Mount the control box firmly to a non-movable object. Knockouts are provided for conduits. Do not mount the control box where a lawn sprinkler may spray water on it.

- ✓ **NOTE:** When installing the cable connecting the operator to the control box, be sure to leave some slack to allow for the swing of the gate. Water tight connectors are highly recommended.

# Gate Layout Illustration

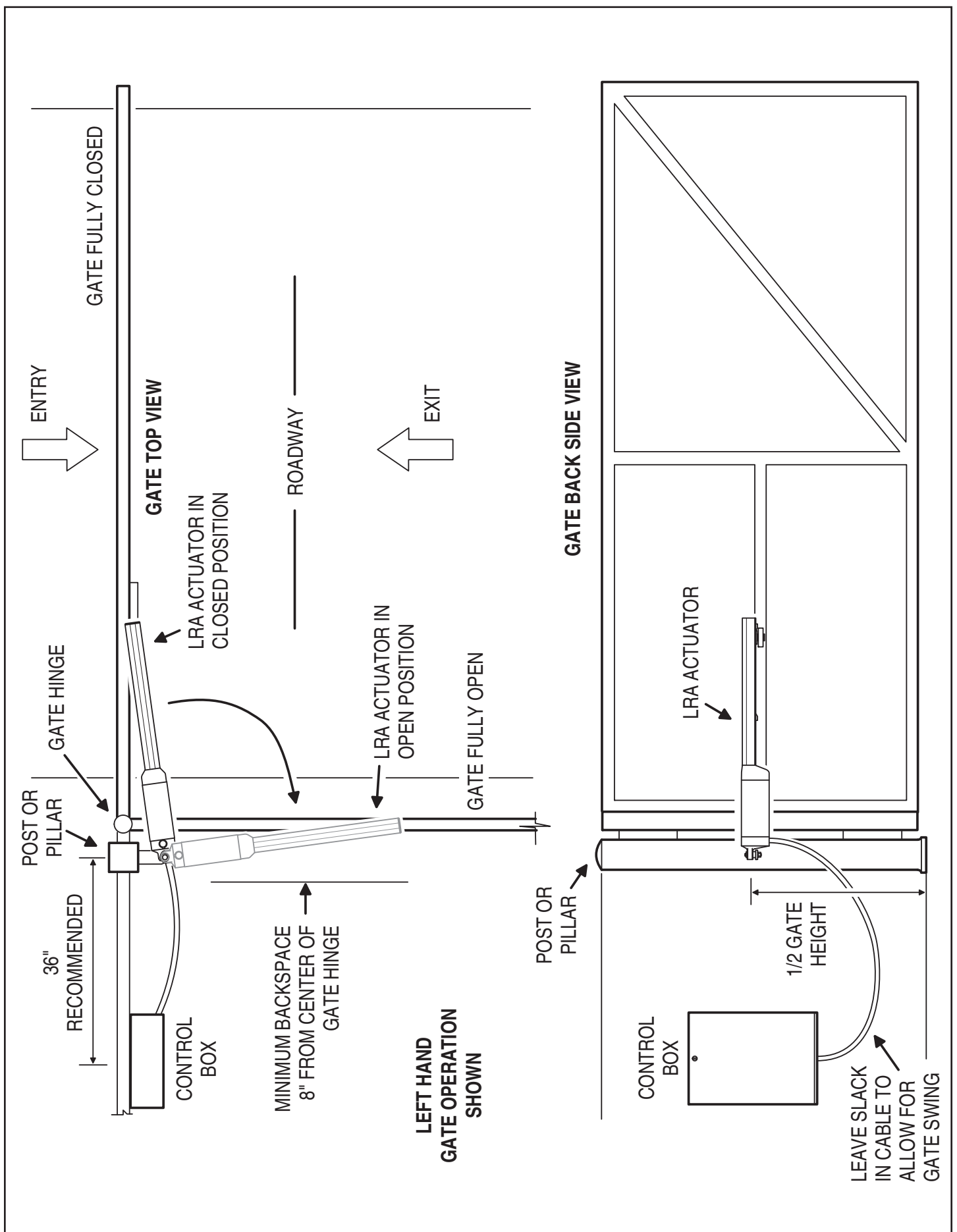

## Mounting Bracket Installation

Examine Figure 2 for details on the required mounting locations for the brackets. They must be mounted at the correct locations to allow the operator to open the gate at a 90 degree angle and to ensure the operator functions smoothly.

The brackets must also be mounted level in respect to each other so the operator's front and rear mounting points are vertical and not offset at an angle.

### **WARNING**

**The gate must be installed in a location so that enough clearance is supplied between the gate and adjacent structures when opening and closing to reduce the risk of entrapment. Swing gates shall not open into public areas.**

1. Measure approximately halfway up the gate height and determine good strong spots located in the required areas to mount the brackets on the post and gate.
  2. Using Figure 2 as a guide, mark the locations on the post or pillar and the gate for the mounting brackets. The top surface of the post bracket must be  $3/8$ " below the top surface of the gate bracket to allow for the bolt-on operator bracket's  $3/8$ " thickness.
- ✓ **NOTE:** Depending on the gate design, an additional reinforcing plate welded to the gate may be required to provide a good spot to mount the gate bracket.

### Universal Post Bracket Installation

- ✓ **NOTE:** When installing the post bracket on a round post or masonry pillar, use improvised methods (additional plate with lag bolts and anchors, concrete wedge anchors, U-bolts, etc.) to securely fasten the bracket.
1. Tack weld the post bracket to the post at the marked spot and double-check its level and height.
  2. Finish welding the post bracket to the gate post and allow the weld to cool.
  3. Attach the bolt-on operator bracket to the post bracket at the correct depth and angle using three bolts and locknuts (there are 18 possible positions). Install the operator bracket pin as shown in Figure 3.

### Gate Bracket Installation

Before welding the gate bracket, be sure the centers of the operator mounting holes on the brackets will end up  $29\text{-}1/2$ " apart when the gate is fully closed.

1. Tack weld the gate bracket to the gate at the marked spot and double-check its level and height.
2. Finish welding the gate bracket to the gate.
3. After the welding is completed and the gate bracket has cooled, snap the limit switch magnet assembly onto the gate bracket (see Figure 4).
4. From the top side of the gate bracket, slide the load bushing into the bracket hole.

### Alternate method to locate the gate bracket:

1. Hold the gate bracket with the magnets installed onto the LRA traveler.
2. Run the unit to the full open position.
3. Place the rear of the arm onto the post bracket.
4. Manually fully open the gate.
5. Position the gate bracket in the required position.
6. Remove the magnet assembly and bolt or weld the bracket in place.

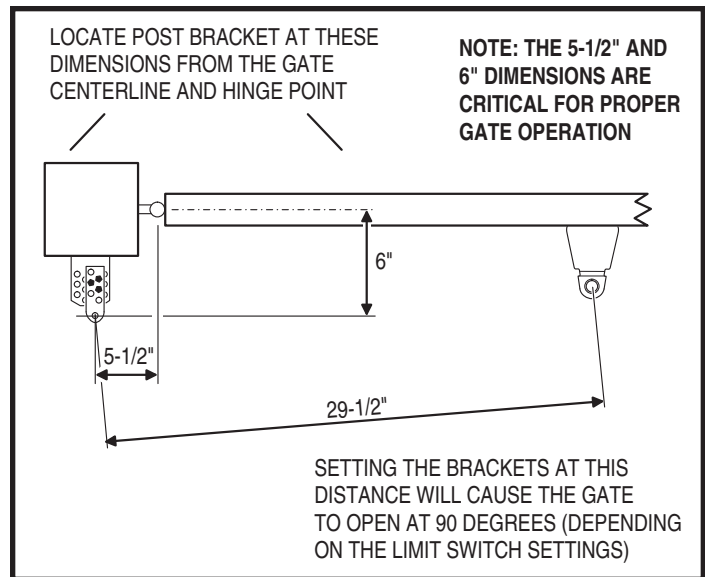

Figure 2. Required Bracket Locations

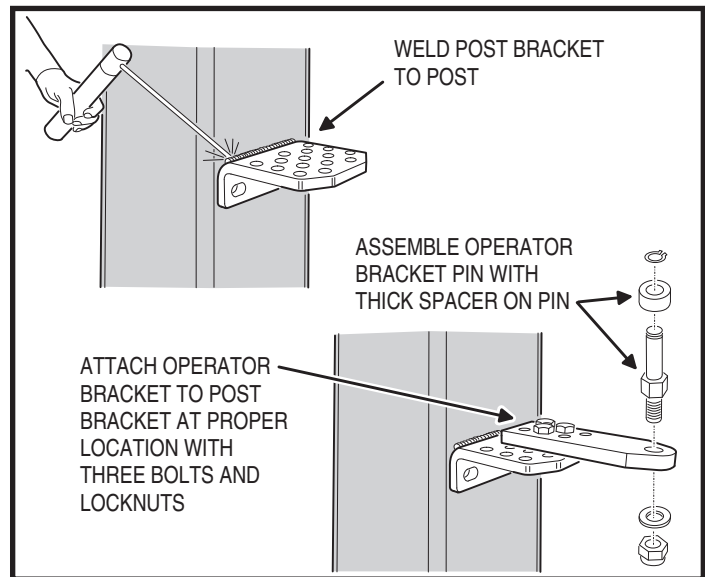

Figure 3. Post Bracket Installation

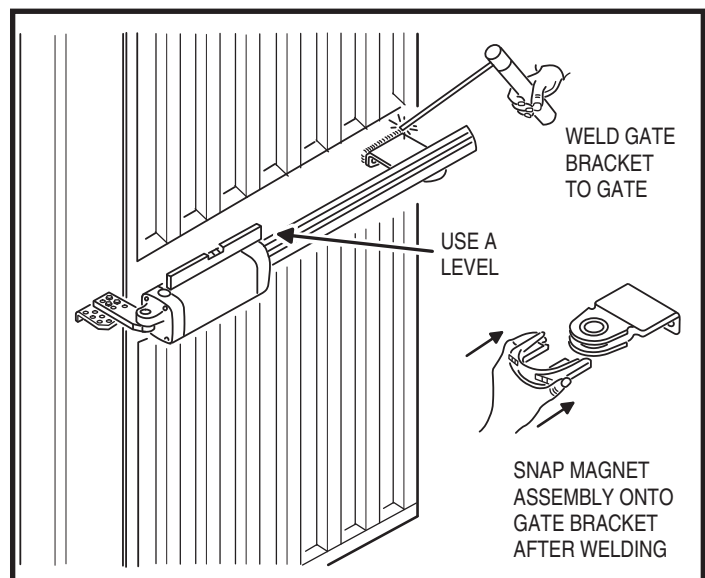

Figure 4. Gate Bracket Installation



# Operator Setup

## Operator Mounting

The operator mounts on the post bracket pin and into the gate bracket bushing. Refer to Figure 5.

1. With the gate closed, carefully position the operator over the mounting brackets.
2. Lower the operator onto the post bracket pin while guiding the operator's worm drive traveler shaft into the gate bracket bushing.
3. Install the washer and clip-ring on the post bracket pin.
4. Install the washer and clip-ring on the traveler shaft.

## Controller Connection

The APeX Controller is mounted in a sealed NEMA4 enclosure. Open the cover for installation access.

The Controller contains two 5-position plug-in terminal blocks for connection to one or two LRA operators. Terminal block **MOTOR-1** is used in single gate LRA installations. Terminal block **MOTOR-2** is used for the second arm in dual gate LRA2 installations.

To make wiring easy, the terminal blocks are removable and plug into the Controller's circuit board.

1. Route the operator cable up through the fluid-tight strain-relief fitting on the bottom of the Controller's cabinet.
2. Noting the wire colors, connect the operator cable to **MOTOR-1** Terminals 1-5 on the Controller.
3. Route the cable towards the operator. Be sure to leave enough slack in the cable to allow for the gate swing.
4. Remove the operator's wiring access plate (see Figure 6).
5. Cut the cable to length if required, then slide the O-ring over the end of the cable.
6. Connect the interface cable to the operator's terminal block matching the same colors and terminal numbers used in Step 2 (see Figure 6).
7. Replace the operator's wiring access plate being careful to align the O-ring below the cable clamp. The O-ring helps keep out moisture.

For dual gate installations, repeat Steps 1-7 and connect the second operator's cable to the **MOTOR-2** 5-position terminal block in the Controller (see Figure 7). Use the strain-relief fitting that comes with the LRA2 kit where the cable enters the Controller cabinet.

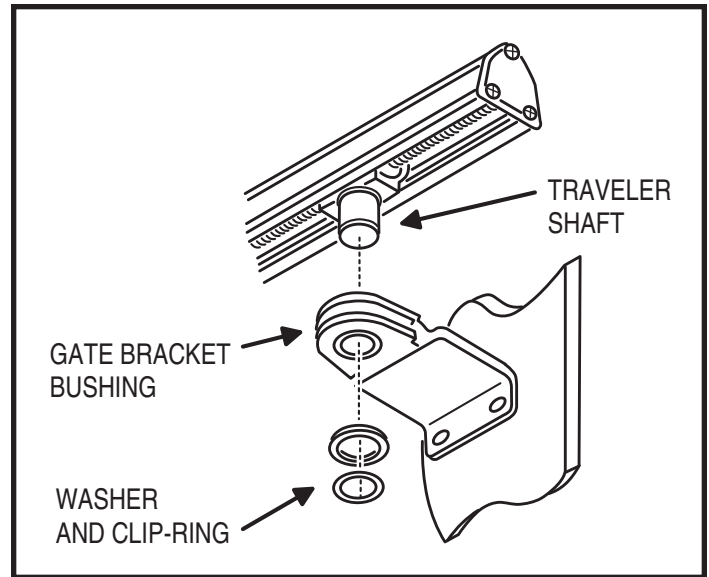

Figure 5. Mounting the Operator

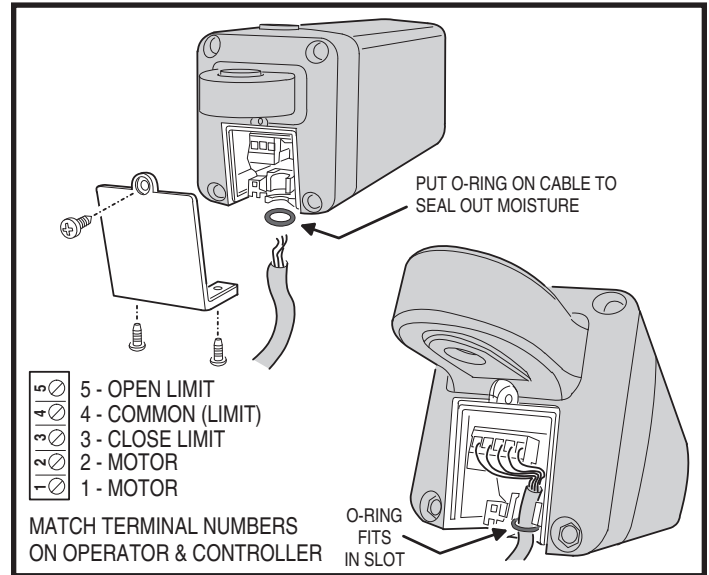

Figure 6. Operator Cable Connections

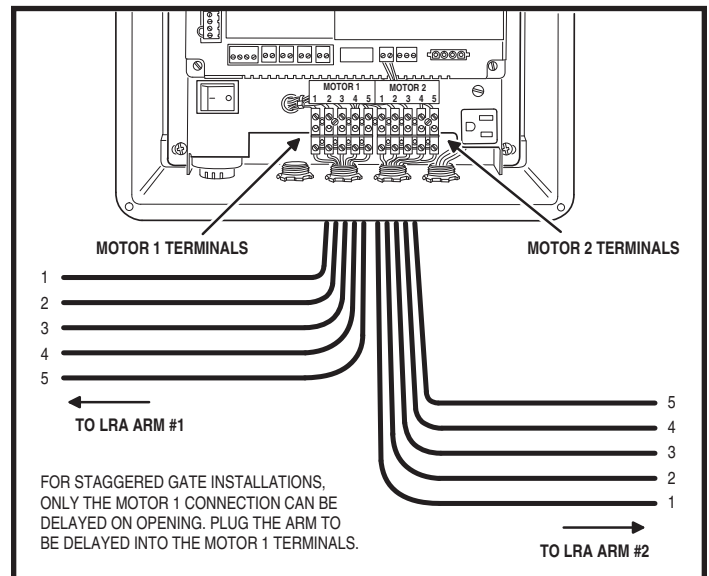

Figure 7. Controller Cable Connections

## Operator Setup (Continued)



**WARNING**



**ALL AC ELECTRICAL CONNECTIONS TO THE POWER SOURCE AND THE OPERATOR MUST BE MADE BY A LICENSED ELECTRICIAN AND MUST OBSERVE ALL NATIONAL AND LOCAL ELECTRICAL CODES.**

### AC Power Connection

The control box contains a power disconnect switch to turn on and off the power available to the operator. Following wiring specifications on Page 2, incoming power should be brought into the control box and connected to the labeled pigtails from the disconnect box. A wiring connections print can be found on the label inside the cover of the operator. See Figure 8 for power option examples.

### Earth Ground

Install a ground rod and connect it to the control box in every installation. A good earth ground is necessary to allow the Controller's built-in surge and lightning protection circuitry to work effectively.

✓ **NOTE:** Do not splice the ground wire. Use a single piece of solid copper 12 AWG wire between the ground rod and the control box.

1. Install an 8-foot long copper ground rod within three feet of the control box.
2. Use a clamp to connect a solid copper 12 AWG ground wire to the ground rod.
3. Route the ground wire to the control box through a wiring knockout.
4. Connect the ground wire to the screw terminal located above the 115V power receptacle on the Controller's metal chassis.

### Manual Disconnect

In case of a power failure or other condition, the gate can be manually moved without action from the operator by using the manual disconnect switch (see Figure 9).

To activate the manual disconnect switch:

1. Open the cover on the switch.
2. Insert the disconnect key (supplied with operator).
3. Turn the key clockwise 90°.
4. Reverse the steps to re-engage the operator.

### Dual Gate Stagger Delay

This feature is used for overlapping dual gates. After completing setup of the operator, in dual gate installations use the following control to adjust the dual gate stagger:

To delay opening of Gate 1, and delay closing of Gate 2, gently adjust the potentiometer located on the motor board (under the small blue removable cover) clockwise until the desired delay is reached (see Figure 10). **Do not turn more than ¼ of a turn or damage will result.** Range is 0 to 10 seconds delay.

Only Motor-1 can be delayed on open. Plug the appropriate LRA arm into either the **MOTOR-1** or **MOTOR-2** terminal block to change which gate is delayed.

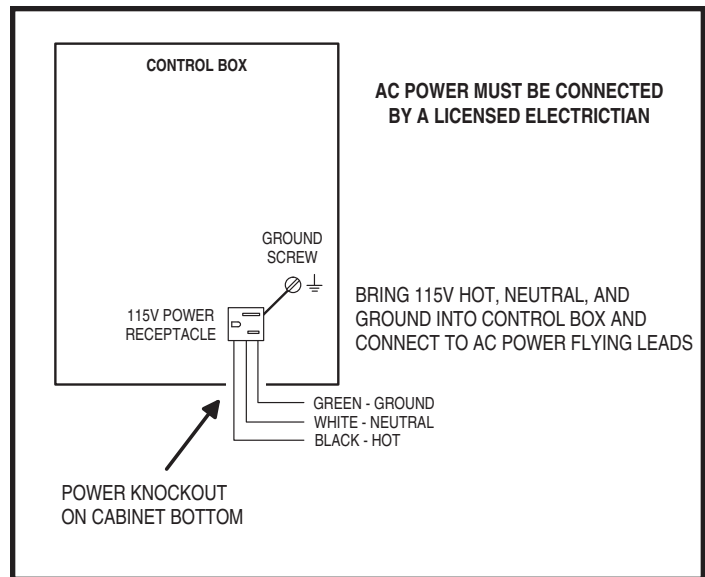

Figure 8. Power and Ground Connections

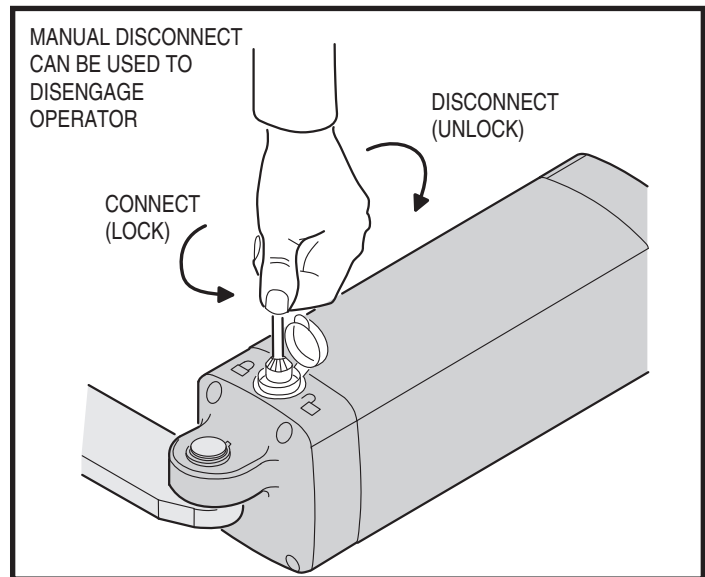

Figure 9. Manual Disconnect

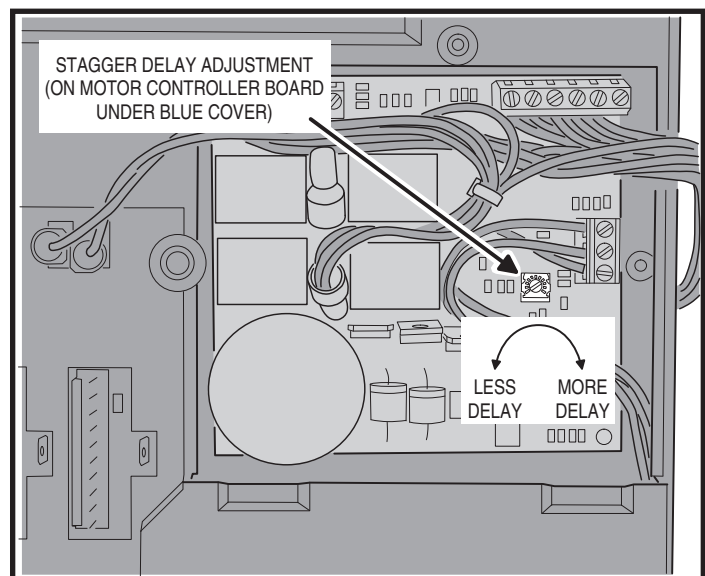
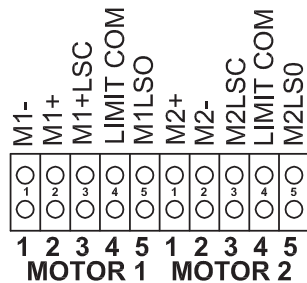
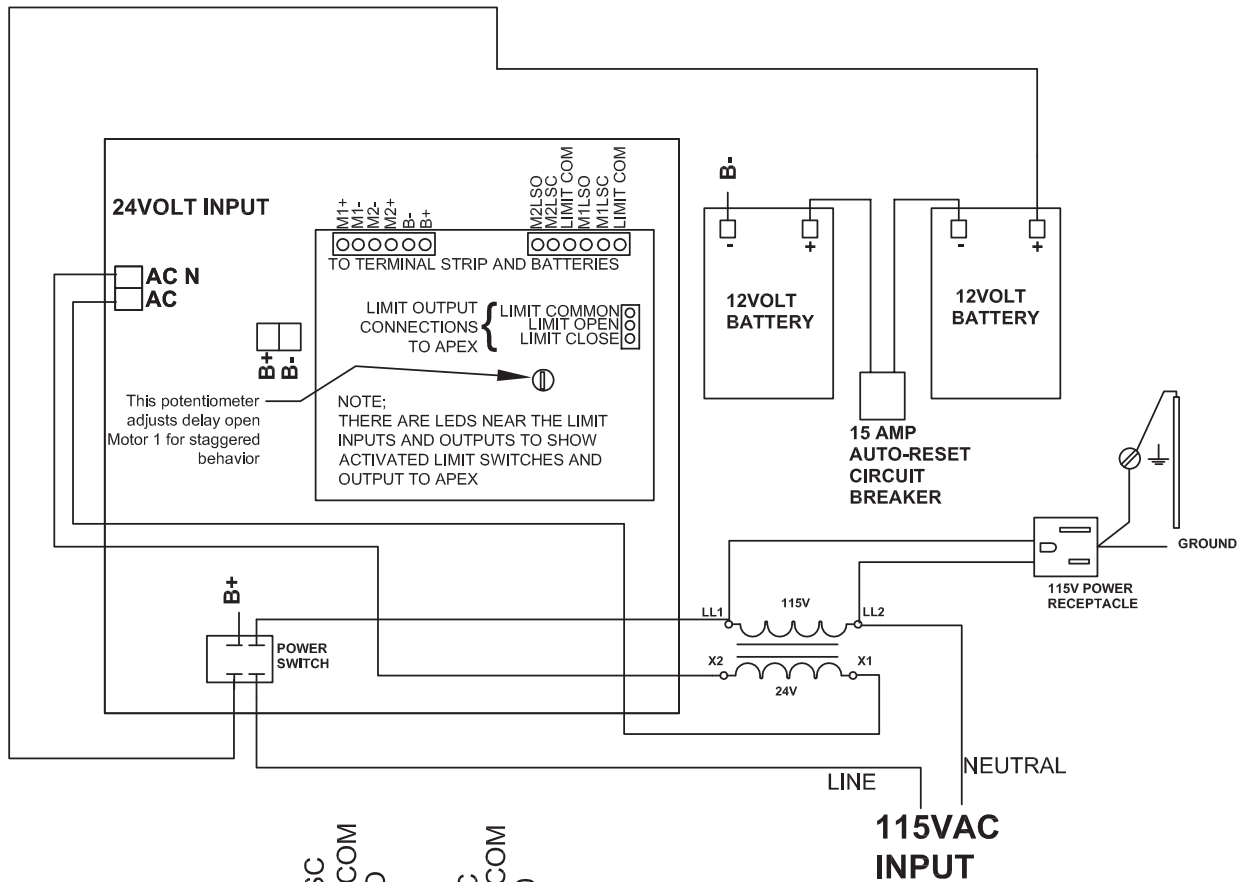
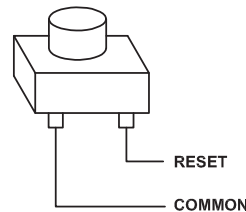

Figure 10. Stagger Delay Control





**STOP/RESET BUTTON CONNECTION**



**ALARM CONNECTION**

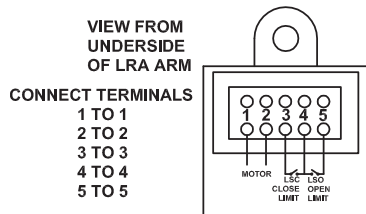
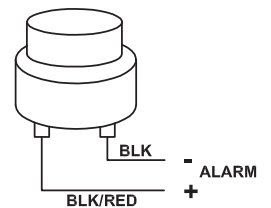

**SINGLE UNIT CAN CONNECT TO EITHER MOTOR 1 OR MOTOR 2 TERMINALS. DUAL MOTORS CONNECT 1 TO EACH SET OF TERMINALS. DO NOT MIX OR JUMPER TERMINALS**

**REMOTE LOCATED POWER SUPPLY**

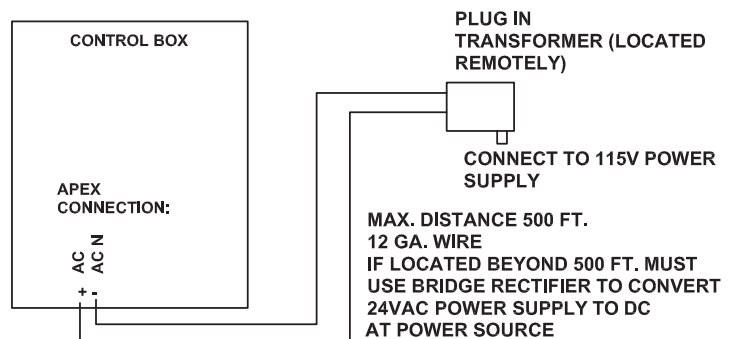

**LRA DUAL CAPABLE WIRING DIAGRAM, 2300-1030 REV C**

## Operator Setup (Continued)

### Limit Switch Adjustment

The open and close limit switches are adjustable by sliding them on the operator's frame. Sliding either switch closer to the center of the operator **decreases** the gate travel.

1. To limit the *opening* travel of the gate for setup, loosen the locking screw on the open limit switch, slide the switch towards the center of the operator (see Figure 11).
2. With the gate closed, apply power to the Controller, **STAY CLEAR OF THE GATE** and press the **OPEN** button.
3. Observe the gate as it opens, and watch the point where it stops.
4. To limit the *closing* travel of the gate for setup, loosen the locking screw on the close limit switch, remove the wire holding plugs from the wire slot in the channel, slide the switch towards the center of the operator (see Figure 12).
5. Be sure to **STAY CLEAR OF THE GATE** and press the **CLOSE** button.
6. Observe the gate as it closes, and watch the point where it stops.
7. Adjust the two limit switches until the open and close stopping points are set correctly for the gate. **TIGHTEN THE LOCKING SCREWS ON THE LIMIT SWITCHES.**

### ⚠ CAUTION ⚠

Be careful not to damage the limit switch wires while adjusting the limit switches. Gently pull the limit switch wire while tightening the limit switch locking screw (see Figure 12).

8. Push any extra limit wire back into the motor housing. Replace the limit switch wire holding plugs to retain the limit switch wire.

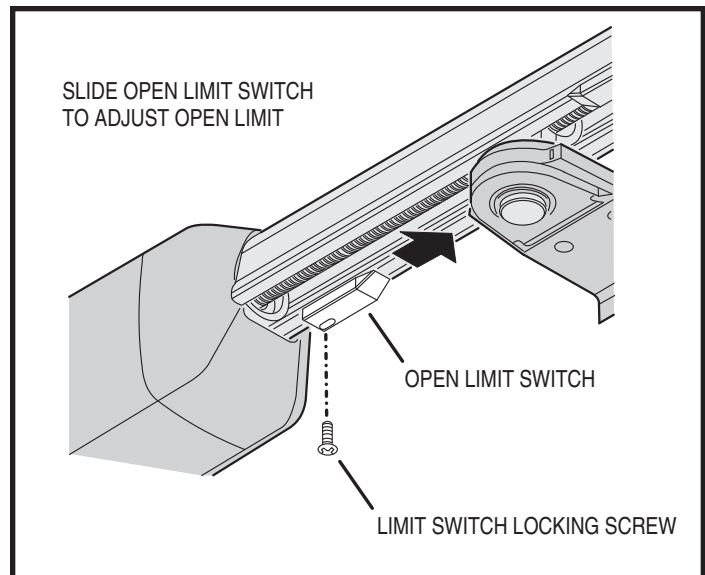

Figure 11. Open Limit Switch

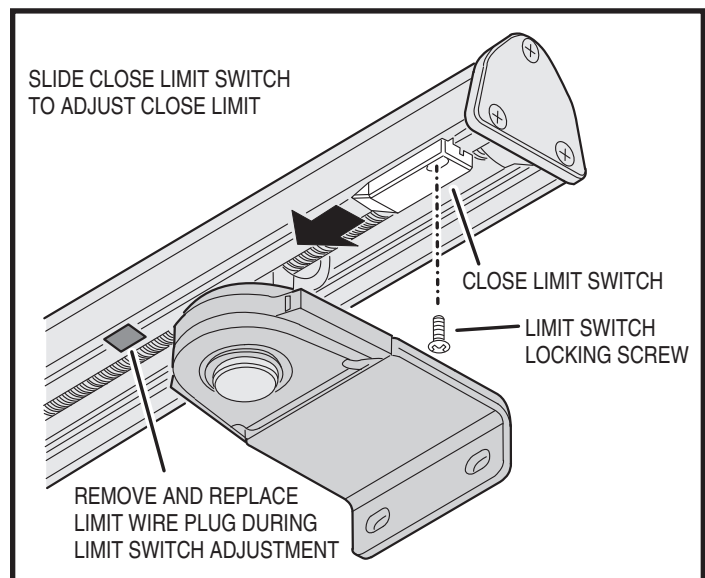

Figure 12. Close Limit Switch

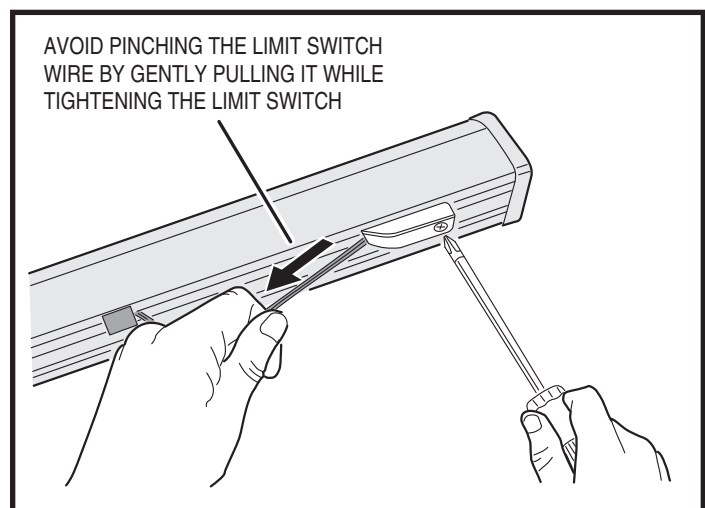

Figure 13. Limit Switch Wire

# Controller Features

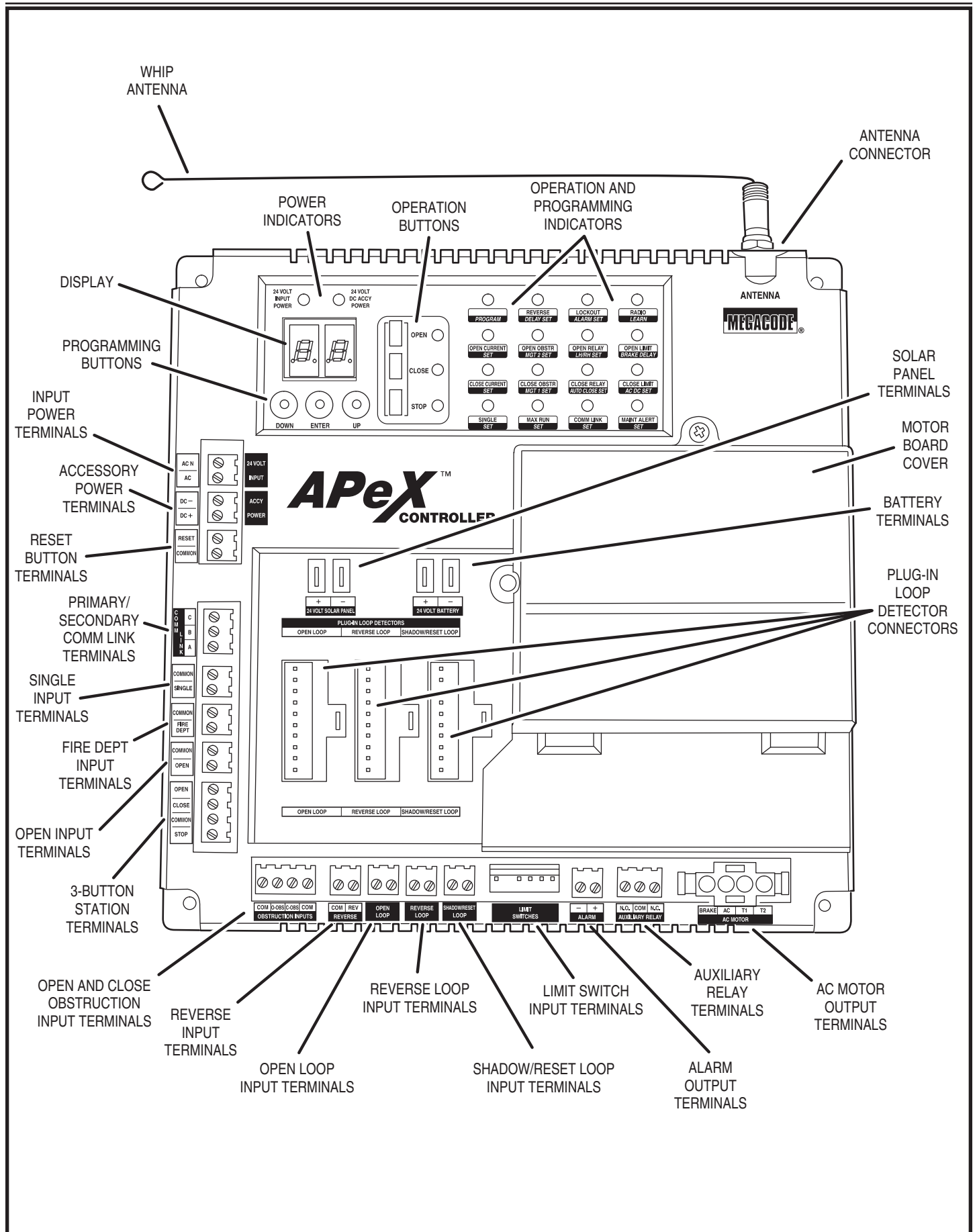

Figure 14. Controller Features

# Indicator Descriptions

INDICATOR DEFINITION		INDICATION WHEN LIT DURING NORMAL OPERATION	INDICATION WHEN LIT DURING PROGRAMMING
OPERATION	PROGRAMMING		
24 VOLT INPUT POWER		LOW VOLTAGE AC POWER IS PRESENT	
24 VOLT DC ACCY POWER		LOW VOLTAGE DC POWER IS PRESENT	
OPEN		OPEN SIGNAL PRESENT FROM THE INTERNAL RECEIVER OR AN EXTERNAL DEVICE CONNECTED TO THE OPEN INPUT TERMINAL	
CLOSE		CLOSE SIGNAL IS PRESENT FROM A DEVICE CONNECTED TO THE CLOSE INPUT TERMINAL	
STOP		STOP INPUT TERMINAL IS OPEN AND NOT CONNECTED TO COMMON	
PROGRAM			CONTROLLER IS IN PROGRAMMING MODE
REVERSE	DELAY SET	SIGNAL FROM REVERSING DEVICE IS PRESENT	SET REVERSE DELAY TIME
LOCKOUT	ALARM SET	CONTROLS AND OPERATOR ARE LOCKED OUT BECAUSE OF EXISTING TROUBLE CONDITION	SET RUN ALARM AND PRE-START ALARM
RADIO	LEARN	BUILT-IN RECEIVER IS DETECTING A RADIO SIGNAL FROM A REMOTE CONTROL	TRANSMITTERS CAN BE ENTERED INTO MEMORY (UP TO 40 TRANSMITTERS)
OPEN CURRENT	SET	MOTOR CURRENT HAS EXCEEDED THE OPEN CURRENT SETTING WHILE OPENING	SET MAXIMUM OPEN CURRENT
OPEN OBSTR	MGT 2 SET	OPEN OBSTRUCTION TERMINAL CONNECTED TO COMMON BY BEAM OR SAFETY EDGE, OR SIGNAL FROM MGT OBSTACLE TRANSMITTER	SET MGT #2 FUNCTION
OPEN RELAY		OPEN RELAY IS ACTIVATED	
OPEN LIMIT	BRAKE DELAY	OPEN LIMIT SWITCH IS ACTIVATED	
CLOSE CURRENT	SET	MOTOR CURRENT HAS EXCEEDED THE CLOSE CURRENT SETTING WHILE CLOSING	SET MAXIMUM CLOSE CURRENT
CLOSE OBSTR	MGT 1 SET	CLOSE OBSTRUCTION TERMINAL CONNECTED TO COMMON BY BEAM OR SAFETY EDGE, OR SIGNAL FROM MGT OBSTACLE TRANSMITTER	SET MGT #1 FUNCTION
CLOSE RELAY	AUTO CLOSE SET	CLOSE RELAY IS ACTIVATED	SET AUTO-CLOSE TIME
CLOSE LIMIT		CLOSE LIMIT SWITCH IS ACTIVATED	
SINGLE	SET	SINGLE TERMINAL CONNECTED TO COMMON BY AN EXTERNAL PUSHBUTTON OR RADIO	SET SINGLE BUTTON INPUT FUNCTION
MAX RUN	SET	MAXIMUM RUN TIMER HAS BEEN EXCEEDED	SET MAXIMUM RUN TIME
COMM LINK	SET	NOT USED IN SINGLE OR DUAL GATE LRA INSTALLATIONS	
MAINT ALERT	SET	MAINTENANCE IS REQUIRED ON OPERATOR	SET MAINTENANCE ALERT CYCLE COUNT

## APEX FUNCTION DISPLAY INDICATIONS

"RL" LEFT OR RIGHT HAND OPERATION	"AD" ADVANCED PROGRAMMING	"LP" LOW POWER MODE	"MO" MOTOR TYPE SELECTION
"PM" SINGLE OR DUAL GATE	"RT" MAXIMUM RUN TIMER	"FS" POWER FAILURE MODE	"RA" RADIO ENABLE
"AC" AUTO CLOSE TIMER	"SB" SINGLE BUTTON INPUT SETUP	"SS" SOFT START/STOP DURATION	"TL" LEARN TRANSMITTERS
"RP" RUN ALARM PRE-START ALARM	"AR" AUXILIARY RELAY MODE	"CT" RESET CYCLE COUNT	"TD" DELETE TRANSMITTERS
"OC" MAXIMUM OPEN CURRENT	"RD" REVERSE DELAY TIME	"MA" MAINTENANCE ALERT TRIGGER	"ML" LEARN MGT TRANSMITTERS
"CC" MAXIMUM CLOSE CURRENT	"CP" CONSTANT PRESSURE MODE	"MT" MID-TRAVEL STOP POSITION	"MD" ERASE MGT TRANSMITTERS
	"SP" SHADOW LOOP OPEN INHIBIT	"AT" ANTI-TAILGATE ENABLE	"CL" RESET TO FACTORY DEFAULTS

## Terminal Descriptions

TERMINAL	GROUP	FUNCTION
AC N	24 VOLT INPUT	FACTORY CONNECTED TO 24 VAC FROM TRANSFORMER OR 24 VDC FROM CONTINUOUS DUTY DC SUPPLY.
AC		
DC -	ACCESSORY POWER	PROVIDES 24 VOLT DC POWER FOR ACCESSORIES. (.5A MAX)
DC +		
RESET	RESET BUTTON	FACTORY CONNECTED TO THE CONTROLLER'S RESET BUTTON.
COMMON		
C	COMM LINK	NOT USED IN SINGLE OR DUAL GATE LRA INSTALLATIONS.
B		
A		
COMMON	SINGLE BUTTON INPUT	CONNECT TO NORMALLY OPEN SWITCH FOR SINGLE BUTTON OPERATION. ALTERNATES BETWEEN OPEN-CLOSE OR OPEN-STOP-CLOSE DEPENDING ON PROGRAMMING.
SINGLE		
COMMON	FIRE BOX INPUT	CONNECT TO NORMALLY OPEN SWITCH IN FIRE BOX FOR FIRE DEPARTMENT ACCESS.
FIRE DEPT		
COMMON	OPEN INPUT	CONNECT TO NORMALLY OPEN DEVICES (KEYPAD, CARD READER, KEYSWITCH, TELEPHONE ENTRY SYSTEM) TO OPEN THE GATE. A CONSTANT OPEN INPUT WILL OVERRIDE THE MID-TRAVEL STOP AND HALT THE AUTO CLOSE TIMER UNTIL RELEASED.
OPEN		
OPEN	3-BUTTON STATION INPUT	CONNECT TO 3-BUTTON STATION FOR OPEN-CLOSE-STOP CONTROL. A CONSTANT OPEN INPUT WILL OVERRIDE THE MID-TRAVEL STOP AND HALT THE AUTO CLOSE TIMER UNTIL RELEASED.
CLOSE		
COMMON		
STOP		
COM	OBSTRUCTION INPUTS	CONNECT TO NORMALLY OPEN DEVICES (GATE EDGE, PHOTO BEAM) TO DETECT AN OBSTRUCTION DURING OPENING. WHILE GATE IS IN MOTION, ANY OPEN OBSTRUCTION SIGNAL WILL CAUSE THE GATE TO STOP, REVERSE A SHORT DISTANCE, AND THEN STOP AGAIN. AT THIS TIME THE AUTO CLOSE TIMER IS DISABLED, AND A RENEWED INPUT WILL BE REQUIRED TO START THE GATE AGAIN. SHOULD THE GATE BE RESTARTED AND THE OBSTACLE SIGNAL OCCUR AGAIN PRIOR TO REACHING A LIMIT, THE GATE WILL STOP AGAIN, LOCKOUT, AND SOUND THE EMERGENCY ALARM.
O-OBS		
C-OBS		FUNCTIONS THE SAME AS THE OPEN OBSTRUCTION, EXCEPT IN THE CLOSING DIRECTION.
COM		
COM	REVERSE	CONNECT TO NORMALLY OPEN DEVICES TO CAUSE A REVERSAL WHEN THE GATE IS TRAVELING CLOSED. THE GATE WILL REVERSE TO THE FULL OPEN POSITION.
REV		
OPEN LOOP	OPEN LOOP	CONNECT TO OPEN LOOP/FREE EXIT LOOP. THE GATE WILL OPEN WHEN THE LOOP IS TRIGGERED, AND REMAIN OPEN AS LONG AS THE LOOP IS TRIGGERED. REQUIRES LOOP DETECTOR
OPEN LOOP		
REVERSE LOOP	REVERSE LOOP	CONNECT TO REVERSE LOOP. TRIGGERING THE LOOP WILL CAUSE A REVERSAL WHEN THE GATE IS TRAVELING CLOSED. THE GATE WILL REVERSE TO THE FULL OPEN POSITION.. REQUIRES LOOP DETECTOR
REVERSE LOOP		
SHADOW/RESET LOOP	SHADOW/RESET LOOP	CONNECT TO SHADOW/RESET LOOP TO KEEP THE GATE IN ITS FULLY OPEN POSITION AS LONG AS THE SIGNAL IS PRESENT. USED TO KEEP GATE OPEN WHILE VEHICLE IS PASSING THROUGH.. REQUIRES LOOP DETECTOR
SHADOW/RESET LOOP		
-	ALARM	FACTORY CONNECTED TO THE ALARM BEEPER.
+		
N.O.	AUX RELAY	FOR CONNECTION TO AUXILIARY DEVICES (MAGNETIC LOCK, SOLENOID LOCK, STROBE LIGHT) FOR ACTIVATION (OR DEACTIVATION) DURING GATE OPERATION.
COM		
N.C.		
+	24 VOLT SOLAR PANEL	FOR CONNECTION TO 24 VOLT SOLAR PANEL FOR BATTERY CHARGING.
-		
+	24 VOLT BATTERY	FACTORY CONNECTED TO BATTERIES IN DC MODEL OPERATORS.
-		



# Operator Accessory Connections

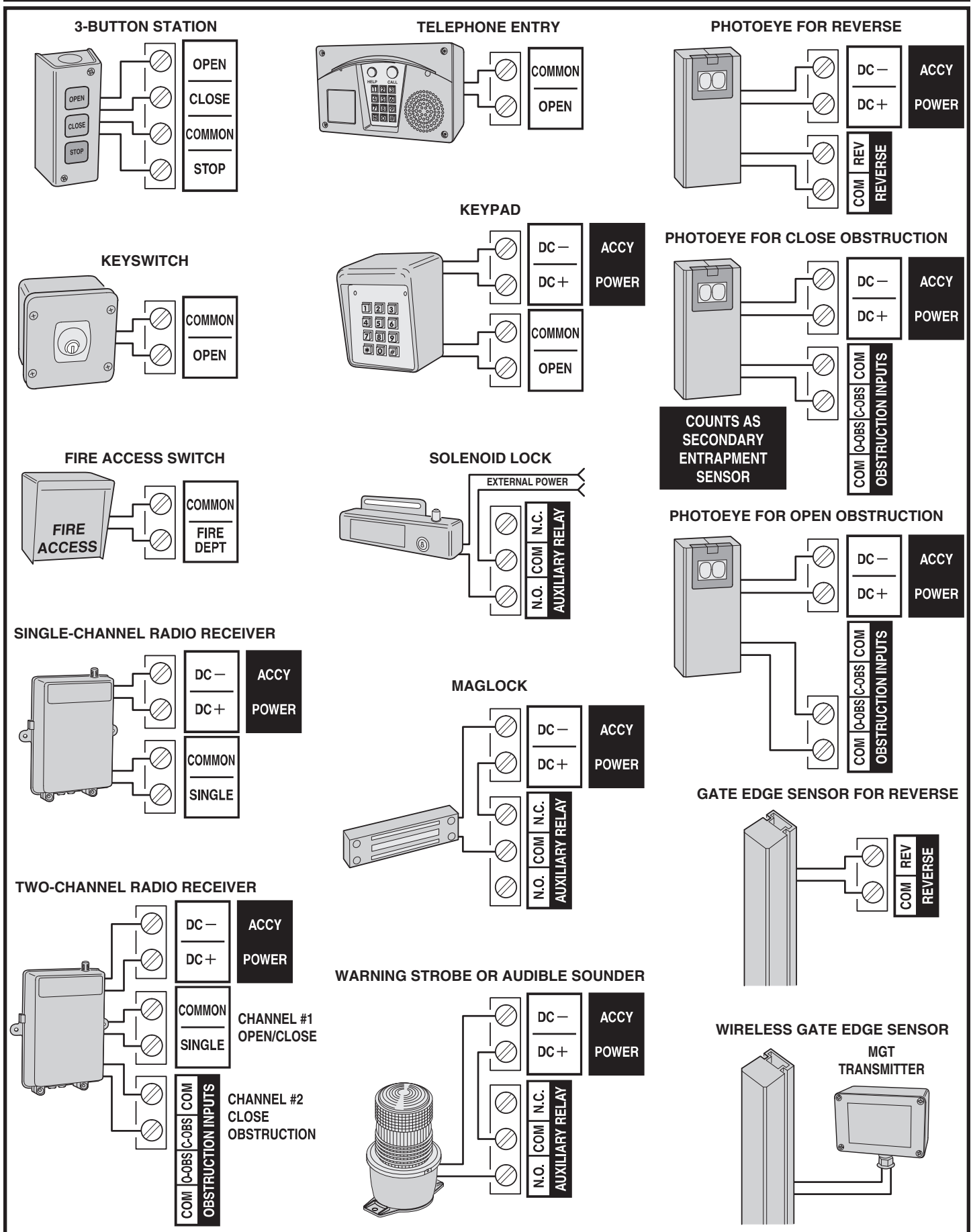

Figure 15. Operator Accessory Connections

# Basic Controller Programming

## Programming Overview

The Controller can be programmed with various options for the operator. The programming fields are defined as “functions” that have “options”. To make setup easier for the installer, the Controller’s programming is divided into two groups: basic and advanced. The basic programming group contains the functions commonly used in most swing gate installations. The advanced programming group contains functions less commonly used (i.e. maximum run timer, etc.).

## Entering Programming Mode

Enter programming mode by pressing the **UP** and **DOWN** buttons together for one second. While in programming mode the **PROGRAM** indicator will light.

## Exiting Programming Mode

Exit programming mode at any time by pressing the **UP** and **DOWN** buttons together. The Controller will automatically exit programming mode after three minutes of inactivity.

## Programming Keystrokes

### (Typical Programming Method)

While in programming mode, press the **UP** or **DOWN** buttons to scroll through the programming functions. When the desired function is displayed press the **ENTER** button to display the currently set option for the function. **When an option is displayed, the decimal points are lit.**

To change the option, press and hold the **ENTER** button for 1 second. To indicate that an option is ready to be changed, the display will flash. While the display is flashing, press the **UP** or **DOWN** button to display the other options available for that function.

When the desired option is displayed, press the **ENTER** button to store it into memory. To select another function, press **ENTER, UP, or DOWN.**

## Left or Right Hand Operation

In typical installations, the LRA pulls the gate to open it inward. **Set the Controller for right hand operation regardless if the installation is a left hand or right hand gate.** This will make the open limit switch on the motor end of the operator. Same for dual gate LRA2 installations.

In some installations, the LRA pushes the gate to open it outward. **Set the Controller for left hand operation regardless if the installation is a left hand or right hand gate.** This will make the close limit switch on the motor end of the operator. Same for dual gate LRA2 installations.

## Dual Gate Enable

This APeX programming function is only used for other models of gate operators. **DO NOT CHANGE THIS SETTING IN ANY LRA INSTALLATION (SINGLE GATE OR DUAL GATE).**

## Auto Close Timer

The factory default turns off the Auto Close Timer. The timer can be set from 1 to 59 seconds and from 1 to 9 minutes. When the Auto Close Timer is set, after opening, the gate will wait for the length of the Auto Close Timer then close automatically.

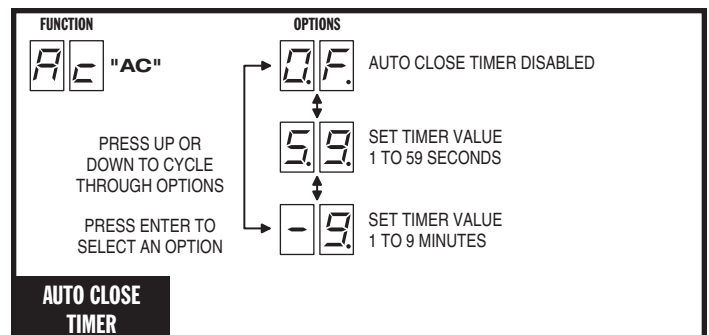
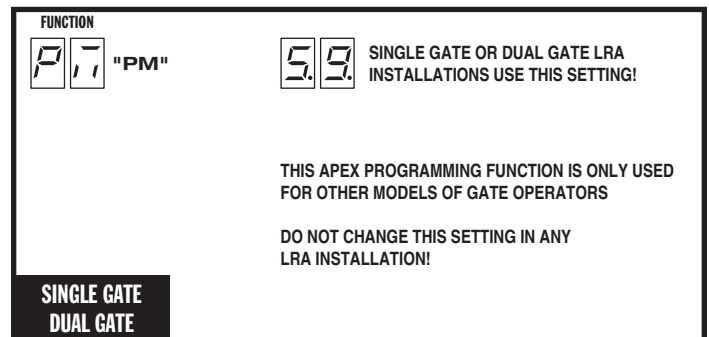
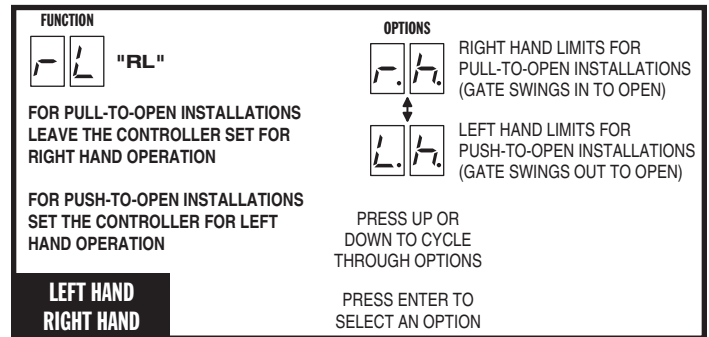
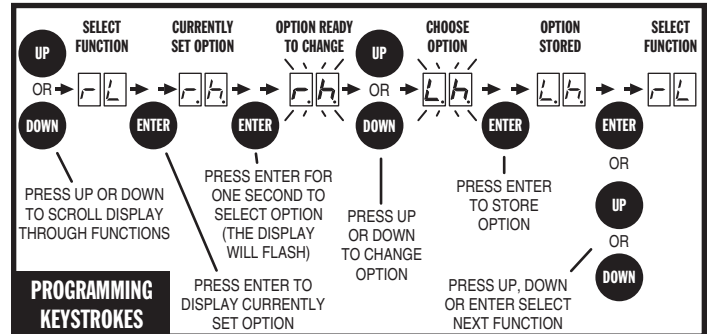
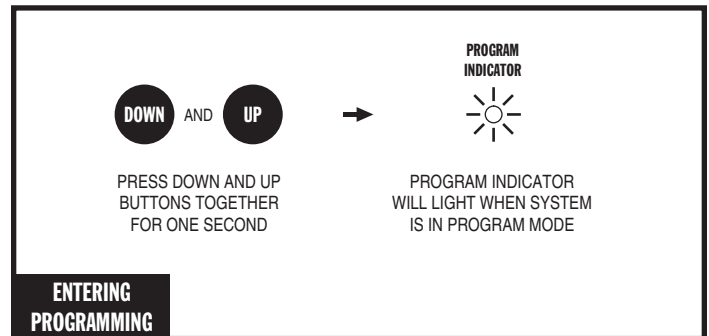

## Basic Controller Programming (Cont.)

### Run Alarm and Pre-start Alarm

The factory default is Run Alarm on and a 3-second Pre-start Alarm. The operator's beeper will sound 3 seconds before the operator starts. The options are:

- Run Alarm Off and Pre-start Alarm Off
- Run Alarm On and Pre-start Alarm Off
- Run Alarm On and Pre-start Alarm On for 1-9 Seconds

### Maximum Open Direction Current Setting

To detect obstacles or mechanical problems with the gate, the operator monitors its motor current. If the open current load exceeds the programmed maximum load range number, the operator will stop, reverse a short distance, then stop again. The Auto Close Timer will be disabled, and another open request will be required to start the operator again. If after restart, the overload or an open obstacle happens again before the open limit is reached, the operator will lockout and sound the alarm.

To measure the motor load used during opening, **while this function is being displayed**, push and hold the **OPEN** button to fully open the gate. During movement, the motor current will be displayed as a load number from 0 to 99. This number is useful for troubleshooting but not for setting the motor current. At the end of travel, a different number will flash. This number indicates the range above and below the average motor current during the run. Using the + and - buttons, set the programmed range number above the indicated range number, so that a minimal force (30-40 lbs. at 10-feet) will activate a reversal should an obstruction occur, but high enough to keep the gate moving under normal conditions without interruption.

### Maximum Close Direction Current Setting

To detect obstacles or mechanical problems with the gate, the operator monitors its motor current. If the close current load exceeds the programmed maximum load range number, the operator will stop, reverse a short distance, then stop again. Another close request will be required to start the operator again. If after restart, the overload or a close obstacle happens again before the close limit is reached, the operator will lockout and sound the alarm.

To measure the motor load used during closing, **while this function is being displayed**, push and hold the **CLOSE** button to close the gate. During movement, the motor current will be displayed as a load number from 0 to 99. This number is useful for troubleshooting but not used for setting the motor current. At the end of travel, a different number will flash. This number indicates the range above and below the average motor current during the run. Using the + and - buttons, set the programmed range number above the measured flashing range number, so that a minimal force (50-75 lbs.) will activate a reversal should an obstruction occur, but high enough to keep the gate moving under normal conditions without interruption.

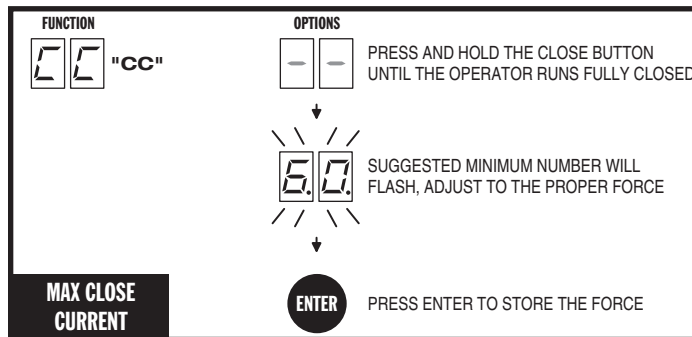
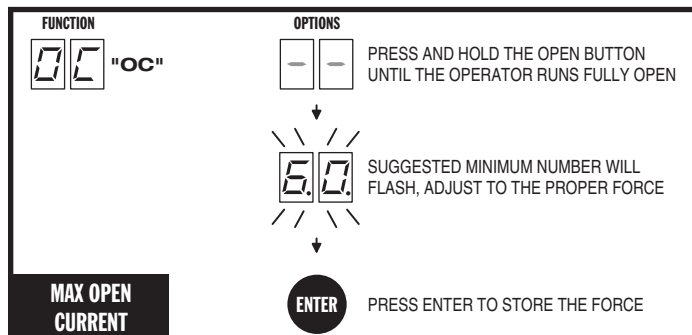
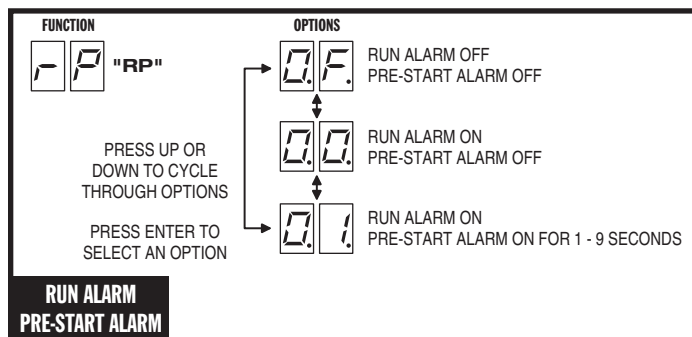

# Advanced Controller Programming

## Entering Advanced Programming Mode

To access and program the Advanced Programming functions, for each programming session, Advanced Programming must be enabled.

After exiting programming, the Advanced Programming functions will be available on the programming display during the next programming session unless the operator has run 50 or more cycles. After that, Advanced Programming must be enabled again.

## Maximum Run Time

The factory default for the Maximum Run Time (MRT) is 99 seconds. When the operator starts, a timer will begin counting. If a open or close limit is not reached or an obstacle or reversing input is not received before the timer expires, the operator will stop, the unit locks out and the alarm sounds. The timer can be set for 10 to 99 seconds, but should be left at 99 in most applications. Setting it too close to the actual run time may cause the time to expire with changing ambient temperature, gate conditions, etc...

If AC is present and an open or close limit is not reached or an obstacle or reversing input is not received before this timer exceeds MRT, the operator will stop, the unit locks out and the alarm sounds.

In the case that AC is not present and MRT expires, it will be ignored as long as the actual run time is under 99 seconds. When the gate reached full open or full close position, MRT will be interpreted as fail safe/secure. EN05 will occur. If FS as set to fail safe, the gate will open. If FS is set to fail secure, the gate will close. However, if the actual run time is higher than 99, it will be interpreted as a physical mechanical problem, EN01 will occur and the gate will stop immediately.

## Single Button Input Setup

This function is used for selecting the operation for single button controls and radio receivers.

The factory default sets the **SINGLE** input terminal so successive inputs will cycle the operator in OPEN-STOP-CLOSE-STOP order.

Alternately, the **SINGLE** input can be set to cause the gate to OPEN unless the gate is fully open. If the gate is fully open, the input will cause the gate to CLOSE.

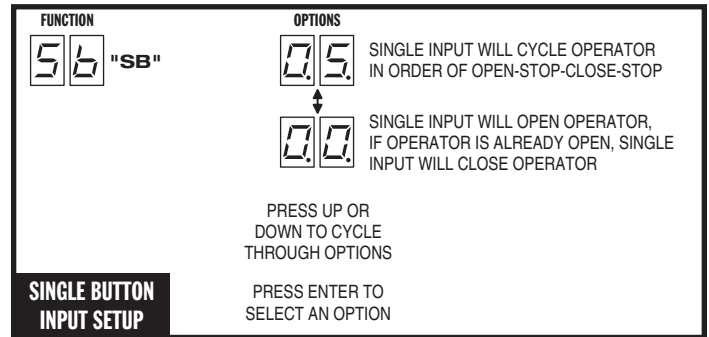
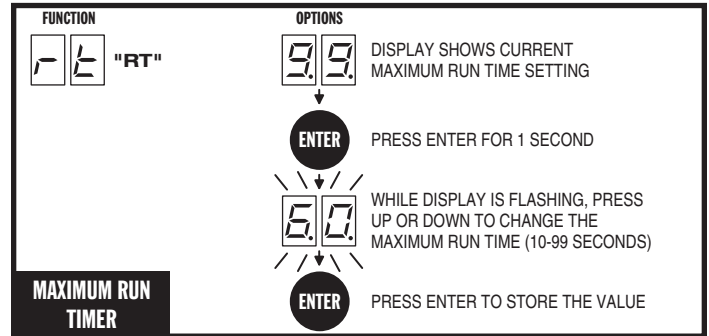
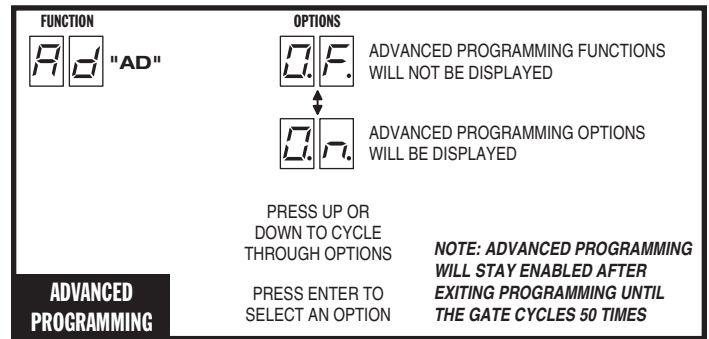

## Advanced Controller Programming (Cont.)

### Auxiliary Relay Mode

The Auxiliary Relay has normally open and normally closed contacts. The factory setting disables the Auxiliary Relay. The relay can be set for:

- **Maglock:** To deactivate a magnetic or solenoid gate lock, the relay will energize during any pending or actual gate motion (open only).
- **M4:** To deactivate a magnetic or solenoid gate lock, the relay will energize during any pending or actual gate motion (open only). 3 seconds after the gate starts to move, the relay will de-energize. This option is used for higher current solenoid locks.
- **Ticket Dispenser:** The relay will energize while the gate is moving in the open direction and at the full open limit, or in an entrapment condition.
- **Strobe:** To activate a warning strobe light, the relay will energize during any pending or actual gate motion (either open or close).
- **Alarm:** The relay will energize if the gate is manually forced open from the full closed position.

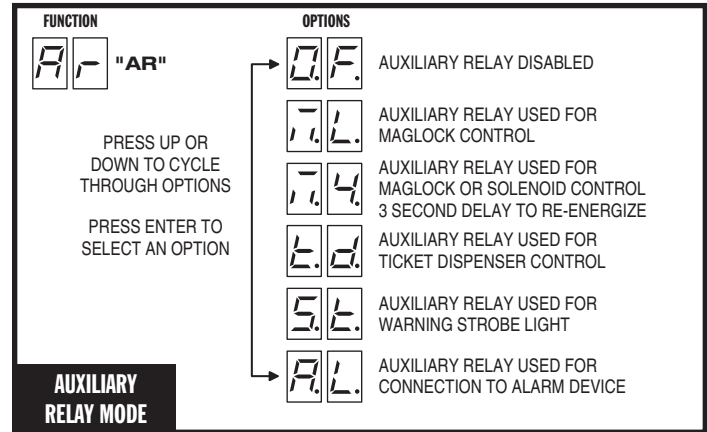

### Reverse Delay Time

The factory default sets the Reverse Delay to 1 second. The operator will wait the length of the delay before reversing direction. This feature will not change the reversal time when the operator is responding to an entrapment condition from an obstruction input or inherent entrapment protection sensor. The Reverse Delay can be set from 1 to 9 seconds. Heaver gates require a longer delay to allow time for the gate to stop.

### Constant Pressure Mode

The factory default allows momentary pressure on a control station's **OPEN** or **CLOSE** button to cycle the operator. The controller can be set to require constant pressure on the **OPEN**, **CLOSE**, or both buttons to run the operator.

- ✓ **NOTE:** If a button is set for constant pressure, and it is released before the operator reaches the open or close limit, the operator will stop the gate at its current position.

### Shadow Loop Open Prevention

If the shadow loop is triggered, it always prevents the gate from *closing* if the Auto Close Timer activates or a **CLOSE** command is given while the gate is at the full open position.

The controller can also be set to prevent the gate from *opening* if the shadow loop is triggered while the gate is at the close limit position. This prevents a swing gate from opening into a vehicle if it's parked near the gate on the inside.

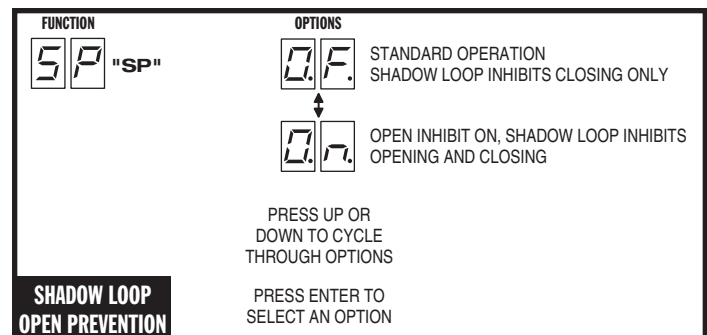
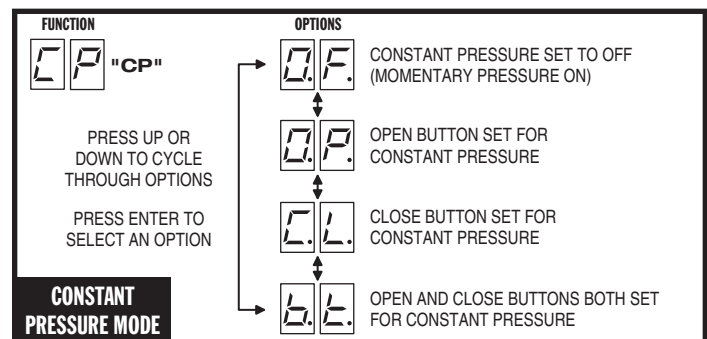
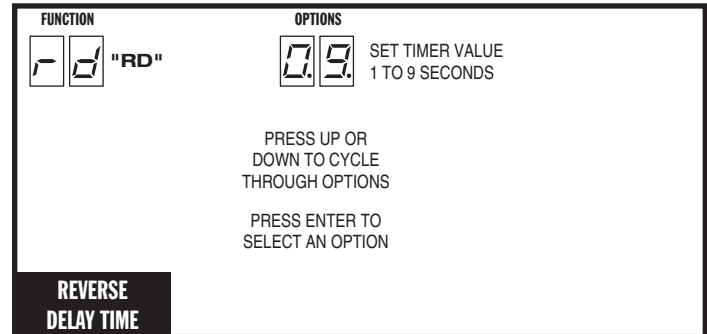



## Advanced Controller Programming (Cont.)

### Low Power Mode

This function is only used with DC battery backup. The factory default disables the Low Power Mode. When Low Power Mode is enabled, and AC power fails, the controller will assume Low Power Mode after 60 seconds of gate inactivity. Low power mode turns off all accessory power and indicators. Only inputs from the radio receiver, reverse loop, open loop (optional by programming), fire department input, or restoring AC power will wake the Controller from Low Power Mode. Programming Mode can still be accessed while the Controller is awake in Low Power Mode.

### Power Failure Mode

This function is only used with DC battery backup. The factory default is set for Fail Safe, alternately the Controller can be set for Fail Secure, Open Immediate, or Close Immediate.

- **Fail Safe:** If the AC power fails and the battery voltage drops below approximately 22 Volts, 5 seconds later the operator will cycle open if not already open. When AC power is restored, or the battery gets charged by solar panels, the operator will resume normal operation and auto-close if programmed to do so.
- **Fail Secure:** If the AC power fails and the battery voltage drops below approximately 22 Volts, 5 seconds later the operator will cycle closed if not already closed. When AC power is restored, or the battery gets charged by solar panels, the operator will resume normal operation.
- **Open Immediate:** If the AC power fails, the operator will cycle open if not already open and cease operation. When AC power is restored, the operator will resume normal operation and auto-close if programmed to do so.
- **Close Immediate:** If the AC power fails, the operator will cycle closed if not already closed and cease operation. When AC power is restored, the operator will resume normal operation.

### Soft Start/Stop Duration

This function causes the operator to start and stop the DC motor slowly reducing gate wear and tear (at the full open or closed positions only). The factory default sets the Soft Start/Stop Duration to 3 seconds. The Soft Start/Stop Duration can be set from 1 to 10 seconds.

- ✓ **NOTE:** Changing the Soft Start/Stop Duration will reset the open and close current setting value to zero. It will be necessary to reprogram maximum open and close current settings.

### Reset Cycle Count

The Controller counts of the number of times the operator has been cycled full open and close. The cycle count can be displayed. The display will scroll the cycle count number, flashing two digits at a time from left to right.

To reset the Cycle Count, press and hold the **ENTER** button for 2 seconds while the Cycle Count is displayed.

If the Maintenance Alert has been triggered, resetting the Cycle Count will also reset the Maintenance Alert indicator.

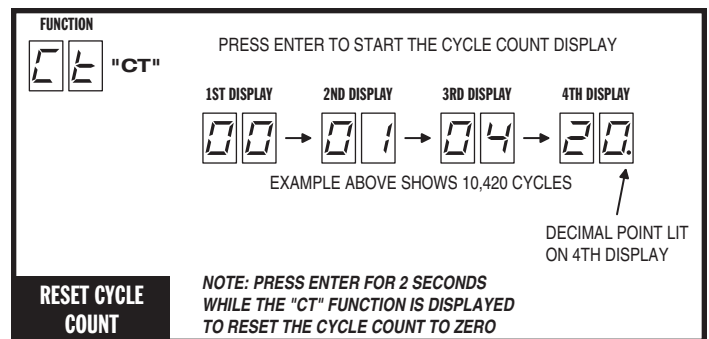
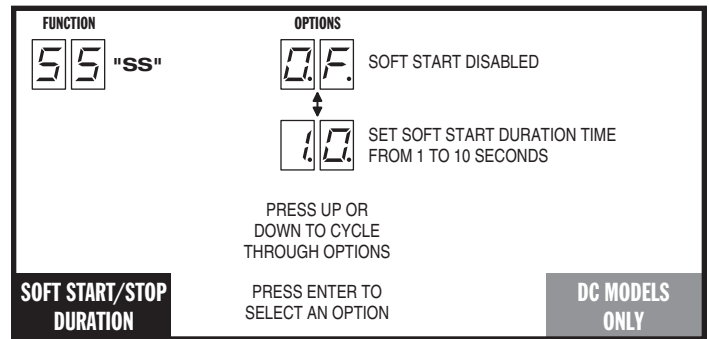
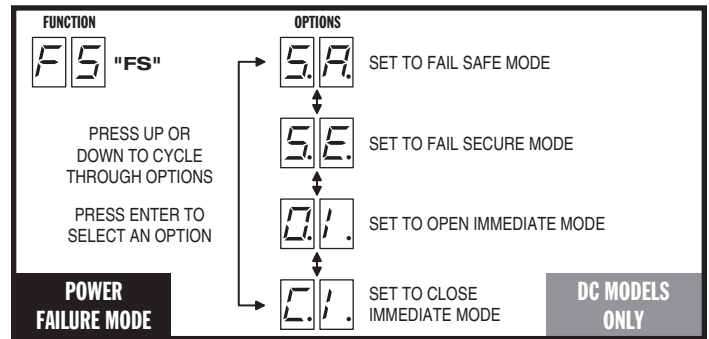
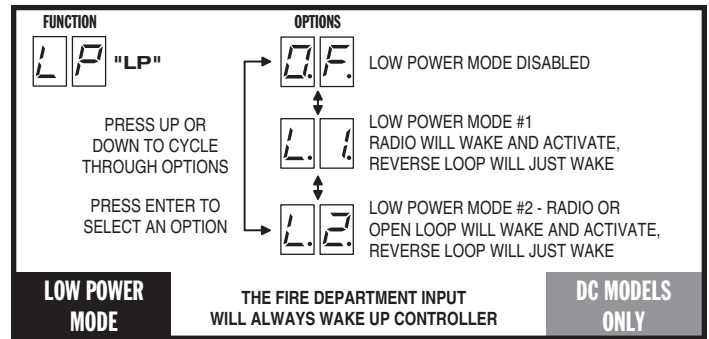

## Advanced Controller Programming (Cont.)

### Maintenance Alert Trigger

The Controller has a **MAINT ALERT** indicator that can be programmed to light when the number of activations exceeds a set number of cycles.

The factory default sets the Maintenance Alert Trigger to 10,000 cycles. The Maintenance Alert Trigger can be programmed for 5, 10, 15, or 25 thousand cycles.

The Maintenance Cycle Count can be reset independently from the operator's absolute Cycle Count.

### Mid-travel Stop Position

The Controller can be programmed so the gate will stop at a mid-travel point instead of fully opening. This can be useful in installations where a large gate, that takes a long time to open and close fully, only needs to be opened partway to allow traffic to pass.

The factory default sets the Controller for full open operation. Alternately, the Controller can be programmed to open for 1 to 99 seconds then stop, before reaching the open limit.

When a Mid-travel Stop Position time has been programmed, the gate will **still fully open** if the Fire Department input is triggered, if the **OPEN** button is held down beyond the Mid-travel Stop Position, or a close obstruction or reverse loop input is triggered.

### Anti-tailgate Enable

The factory default sets the Anti-tailgate Enable to OFF. With this setting, during a gate cycle, after the shadow loop has been triggered by the vehicle and then has cleared after the vehicle passes, the Auto Close Timer or a CLOSE command is required to begin closing the gate.

If the Anti-tailgate Enable is set to ON, the gate will close immediately as soon as the shadow loop has cleared. Any subsequent shadow loop triggers while the gate is closing will stop the gate. When the shadow loop clears, the gate will continue closing.

### Motor Type Selection

The factory sets the default for the Controller to match the type of motor in the operator. **When the Controller is used with the Model LRA Linear Residential Actuator leave this setting at the factory default.**

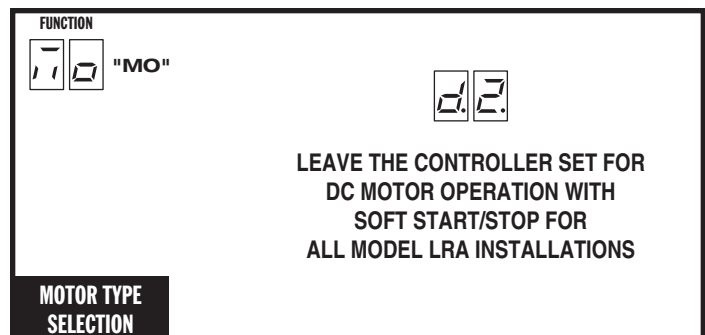
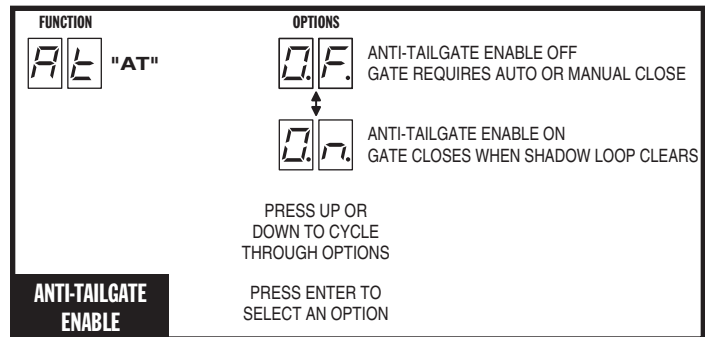
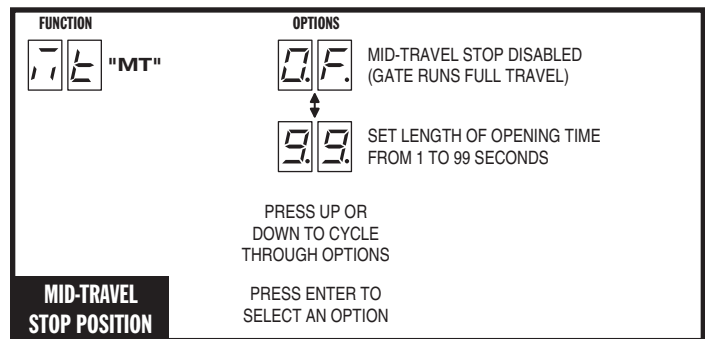
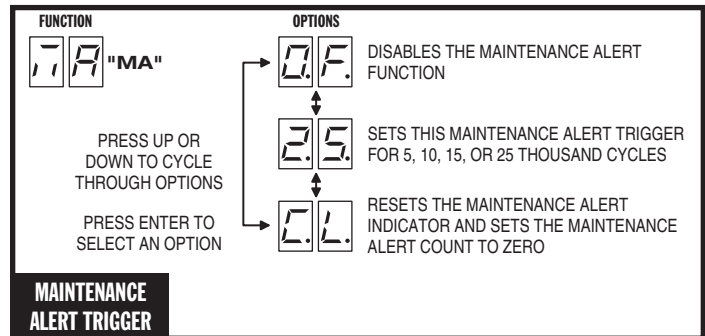

# Advanced Controller Programming (Cont.)

## Radio Enable

The Controller contains a built-in MegaCode® radio receiver to allow activation from up to 40 access control transmitters and two Model MGT (gate edge) transmitters. The factory default enables the internal radio receiver. Alternately, the internal receiver can be disabled.

## Antenna Installation

The Controller is supplied with a local whip antenna. Connect it to the **ANTENNA** connector. If using a remote antenna, connect coax cable from the antenna to the **ANTENNA** connector.

## Radio Transmitter Learn

The Controller's built-in MegaCode® radio receiver can store the IDs of up to 40 transmitters. Refer to the figure for the steps required to learn transmitters.

✓ **NOTE:** This function will NOT be displayed if the transmitter memory is full, or if the radio receiver is disabled.

## Radio Transmitter Delete

Transmitters can be deleted from the Controller's memory either individually, or all at the same time. Refer to the figure for the steps required to delete transmitters.

✓ **NOTE:** This function will NOT be displayed if no transmitters are stored in memory, or if the radio receiver is disabled.

## MGT Obstacle Transmitter Learn

The Controller supports one or two Model MGT Obstacle Transmitters. The transmitters can be programmed to function as Open Obstruction, Close Obstruction, Reverse, or Stop. Refer to the figure for the steps required to learn MGT transmitters.

✓ **NOTE:** This function will NOT be displayed if two MGT transmitters are already stored in memory, or if the radio receiver is disabled.

## MGT Obstacle Transmitter Delete

MGT transmitters can be deleted from the Controller's memory either individually, or all at the same time. Refer to the figure for the steps required to delete MGT transmitters.

✓ **NOTE:** This function will NOT be displayed if no MGT transmitters are stored in memory, or if the radio receiver is disabled.

## Reset Controller to Factory Defaults

The Controller can be reset with this function. **ALL PROGRAMMED DATA WILL BE LOST**, and the factory defaults will be loaded. This function will not erase radio transmitters, current sense values, or motor type. Transmitters must be deleted with the two functions above.

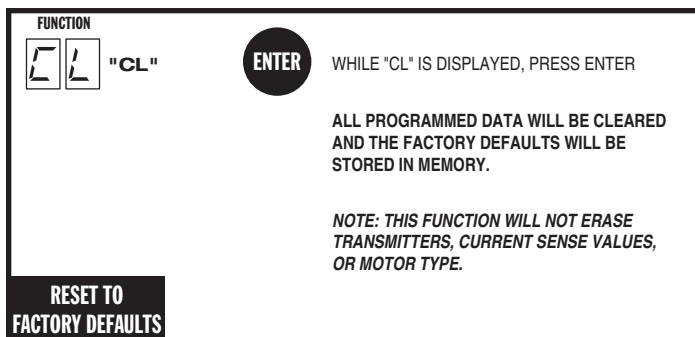
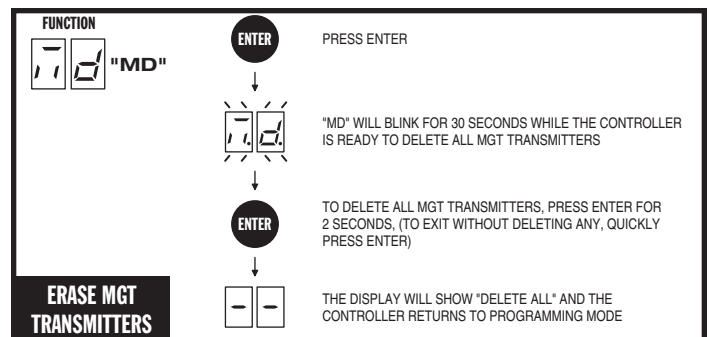
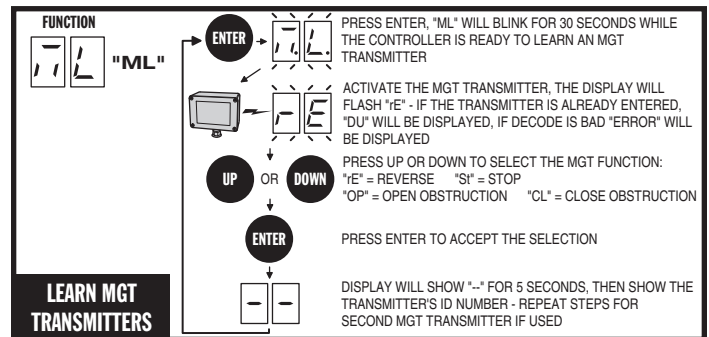
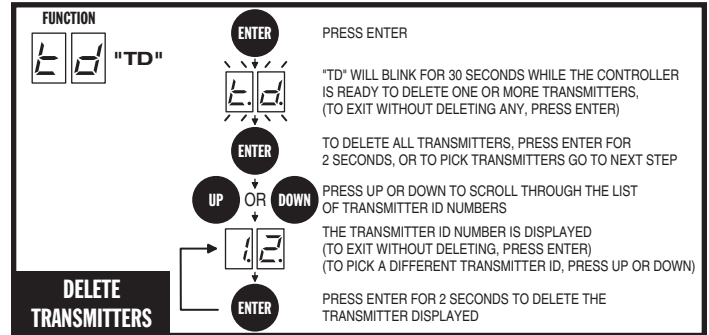
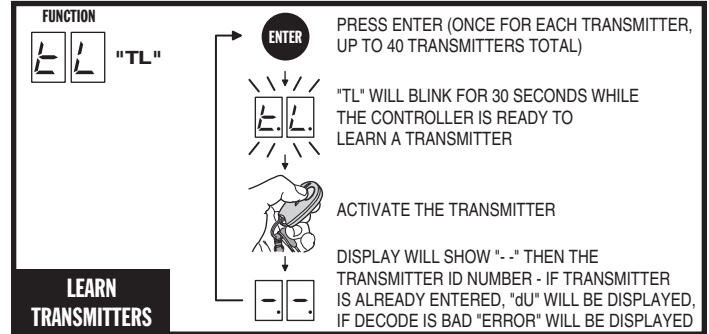
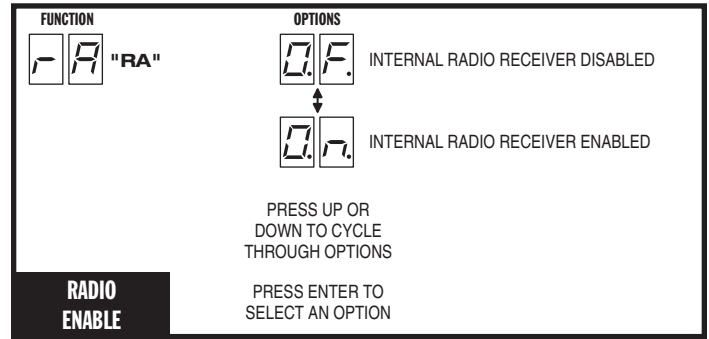

# Loop Layout Illustration

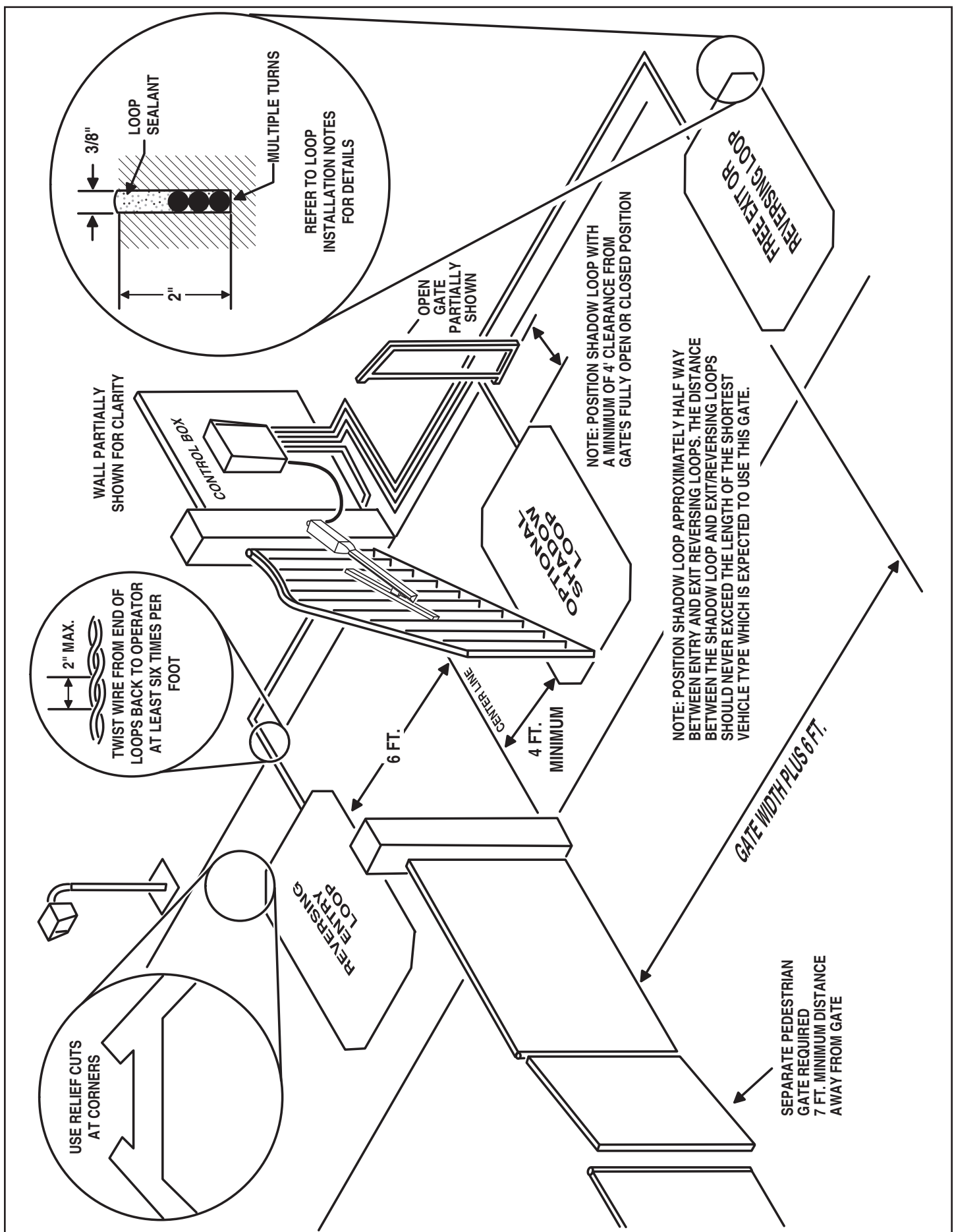

# Safety Edge Layout Illustration

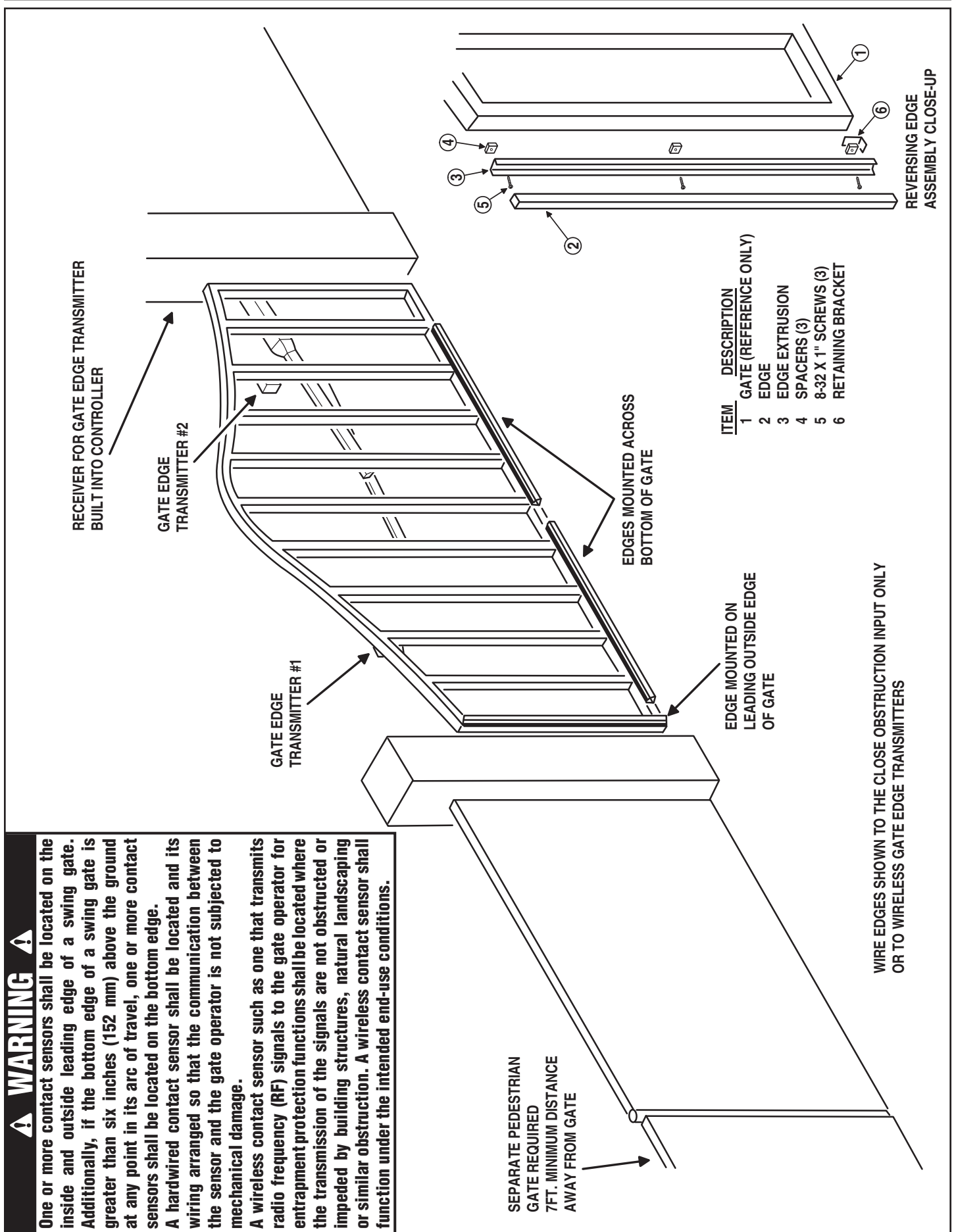

**! WARNING !**

One or more contact sensors shall be located on the inside and outside leading edge of a swing gate. Additionally, if the bottom edge of a swing gate is greater than six inches (152 mm) above the ground at any point in its arc of travel, one or more contact sensors shall be located on the bottom edge.

A hardwired contact sensor shall be located and its wiring arranged so that the communication between the sensor and the gate operator is not subjected to mechanical damage.

A wireless contact sensor such as one that transmits radio frequency (RF) signals to the gate operator for entrapment protection functions shall be located where the transmission of the signals are not obstructed or impeded by building structures, natural landscaping or similar obstruction. A wireless contact sensor shall function under the intended end-use conditions.



# Photoeye Installation Illustration

THIS DRAWING IS INTENDED TO DRAW ATTENTION TO POSSIBLE LOCATIONS FOR THE INSTALLATION OF CONTACT OR NON-CONTACT OBSTRUCTION SENSING DEVICES. OTHER AREAS OF ENTRAPMENT MAY EXIST DEPENDING ON EACH SPECIFIC INSTALLATION.

CARE MUST BE TAKEN TO POSITION PHOTOEYES SO THAT NUISANCE TRIPPING IS MINIMIZED.

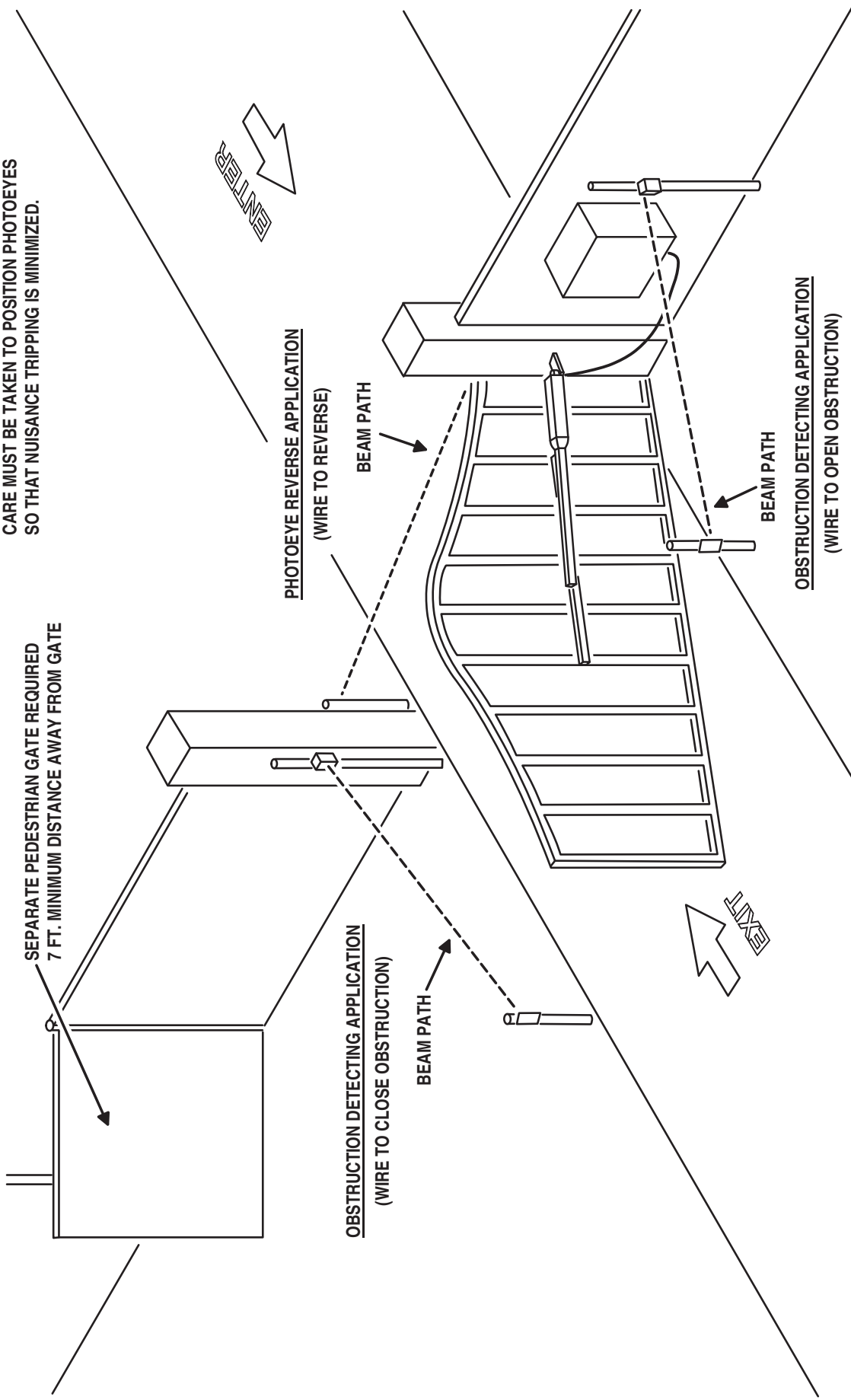

REFER TO CONNECTION ILLUSTRATIONS FOR DETAILS

## Gate Operation

---

### **Open Button**

Opens the gate. If the Controller is programmed to stop opening the gate at mid-travel, a constant press of the **OPEN** button will override the Mid-travel Stop and completely open the gate. If the Auto Close Timer is set, it will be suspended until the **OPEN** button is released.

### **Close Button**

Closes the gate if the gate is open. Also closes the gate if the gate is in the process of opening.

### **Stop Button**

Stops the gate from opening or closing at any time.

### **Single Input**

Opens the gate if it's closed and closes the gate if it's open (open-close programming option). Activating the input while the gate is moving will reverse the gate.

Can be programmed to stop the gate while the gate is moving (open-stop-close programming option).

### **Fire Department Input**

Fully opens the gate when the input is activated. Overrides the Mid-travel Stop and Auto Close Timer (if either is programmed for the gate). The gate will lockout in the open position without sounding the alarm. Press the **STOP** button to release the lockout.

### **Open Input**

Functions the same as the **OPEN** button.

### **Open Obstruction**

While the gate opening, any open obstruction signal will cause the gate to stop, reverse a short distance, and then stop again. The Auto Close Timer will be disabled, and a renewed input will be required to start the gate again. Should the gate be restarted and the obstacle signal occur again prior to reaching a limit, the gate will stop again, lockout, and sound the emergency alarm.

### **Close Obstruction**

Same as the open obstruction, but in the closing direction.

### **Reverse Input**

If the reverse input is triggered while the gate is closing, the gate will reverse to the full open position. If the Auto Close Timer is set, when the reverse input is cleared, the gate will close when the Auto Close Timer expires.

### **Open Loop**

Functions the same as the **OPEN** button.

### **Reverse Loop**

Functions the same as the reverse input.

### **Shadow/Reset Loop**

Holds the gate fully open or fully closed while triggered. If open, the gate closes immediately when cleared if Anti-tailgate is enabled.

## Operation Indications

---

During normal operation, the Controller's displays will indicate current operating conditions and status.

### **Power-up Display**

When the Controller powers up, dashes will show on the display, then the firmware version number, then the gate type (SL for slide and swing gates).

Exiting programming restarts the Controller. The power-up display will show upon the restart.

### **Idle Condition**

While the Controller is idling, waiting for a command, the display will show circulating dashes.

For DC models only - Clockwise : Batteries discharging,  
Counterclockwise : Batteries charging

### **Last Gate Position/Condition**

When the gate moves or stops, the display will show the status for up to one minute.

- Stop is displayed as  $S\bar{L}$
- Full Close is displayed as  $F\bar{C}$
- Full Open is displayed as  $F\bar{O}$
- Entrapment is displayed as  $E\bar{n}$

### **Pre-start Delay**

During the pre-start delay, the display will countdown the number of seconds remaining before the operator starts.

### **Reverse Delay**

If the gate travel direction is reversed from a user activation or reversing device, and a reverse delay is set, the display will count down the delay time in seconds before the operator restarts.

### **Run Timer**

While the gate is opening or closing, the number of seconds running time is displayed.

## Error Indications

During abnormal operation, the Controller's displays and beeper will indicate the error condition that has occurred.

### Entrapment

If an entrapment condition occurs detected by two repeated open or close obstruction triggers, the Controller will lock the operator out. The beeper will sound constantly and the gate will not operate. To reset the Controller press the **STOP** button or press the **RESET** button on the control box.



### WARNING



**The Stop and/or Reset button must be located in the line-of-sight of the gate. Activation of the reset control shall not cause the operator to start.**

### MGT Obstacle Transmitter Trouble

If any MGT transmitters are used with the operator, their supervision feature will alert the Controller if there is any trouble with the transmitter. MGT transmitters send hourly status reports and will send low battery reports when the transmitter has a low battery. The MGT transmitters also have a tamper detection switch that will trigger when their case is opened.

When the Controller detects a low transmitter battery, a tamper signal, or missing transmitter status reports, the gate will still operate normally, but the beeper will change as follows:

- The Pre-start Alarm will beep twice as fast.
- The Run Alarm will beep twice as fast and continue for five minutes after the gate stops.
- The sounder will "chirp" every five seconds when the gate is idle.

Correct the trouble (close case, replace battery, or replace transmitter) to clear the obstacle transmitter trouble indications.

### Maximum Run Time Exceeded

If the Maximum Run Time is exceeded, the Controller stops the operator the same as if a double obstacle has occurred in an entrapment condition. The entrapment alarm sounds constantly, and is cleared by pressing the **STOP** button or the **RESET** button on the cover. After the **STOP** or **RESET** button is pressed, because the Maximum Run Time has been exceeded, the sounder will beep twice every five seconds. The next operation of the gate will clear the indication.

CONTROLLER ERROR CAUSES AND INDICATIONS		
ERROR CAUSE	ERROR INDICATION	HOW TO CLEAR
TWO SAFETY REVERSALS (ON SINGLE GATE OR ON EITHER DUAL GATE)	$E_n 00$ , CONTINUOUS ALARM BEEPER, GATE DISABLED	PRESS STOP BUTTON
MAXIMUM RUN TIMER EXCEEDED ON OPENING	$E_n 01$ , AND <b>MAX RUN</b> LED, CONTINUOUS ALARM BEEPER, GATE DISABLED	PRESS STOP BUTTON, CLEARS CONTINUOUS ALARM, THEN DOUBLE BEEP EVERY 5 SECONDS UNTIL NEXT OPERATION
MAXIMUM RUN TIMER EXCEEDED ON CLOSING	$E_n 02$ , AND <b>MAX RUN</b> LED, CONTINUOUS ALARM BEEPER, GATE DISABLED	PRESS STOP BUTTON, CLEARS CONTINUOUS ALARM, THEN DOUBLE BEEP EVERY 5 SECONDS UNTIL NEXT OPERATION
COMM LINK FAILURE	$E_n 03$ , AND <b>COMM LINK</b> LED, CONTINUOUS ALARM BEEPER FOR 1 MINUTE, GATE DISABLED (EXCEPT FOR FIRE DEPT INPUT)	COMM LINK NOT USED IN LRA DUAL GATE INSTALLATIONS. BE SURE APEX IS SET FOR SINGLE GATE.
GATE FULL OPEN RESULTING FROM FIRE DEPT INPUT	$E_n 04$ , GATE DISABLED	PRESS STOP BUTTON
FAIL SAFE OR FAIL SECURE BECAUSE OF BATTERY VOLTAGE DROP BELOW 21.6 VDC DUE TO AC POWER LOSS	$E_n 05$ , GATE DISABLED	BATTERY VOLTAGE MUST RISE ABOVE 24 VDC
OTHER CONTROLLER IN ENTRAPMENT (DUAL GATE)	$E_n 06$ , GATE DISABLED	CLEAR ENTRAPMENT ON OTHER CONTROLLER (PRESS STOP)
LOW AC VOLTAGE AT CONTROLLER	$E_n 07$ , GATE DISABLED	RESTORE AC POWER TO NORMAL LEVEL
INPUT TRIGGERED DURING ENTRAPMENT LOCKOUT	$E_n 08$ , GATE DISABLED	PRESS STOP BUTTON
COMPATIBILITY PROBLEM	$E_n 09$ , GATE DISABLED	UPDATE FIRMWARE AND RESET BOTH PAIRED CONTROLLERS
EEPROM PROBLEM	$E_n 10$ , GATE DISABLED	TRY RESET, CALL TECH. SUPPORT
DC MOTOR MISMATCH	$E_n 11$ , GATE DISABLED	REPROGRAM MOTOR TYPE OR CHANGE DC MOTOR BOARD, NEXT GATE MOVEMENT WILL RETRY DC MOTOR CHECK
MOTOR FAILURE	$E_n 12$ , GATE DISABLED	REPLACE MOTOR
AC POWER LOSS IN OPEN OR CLOSE IMMEDIATE POWER FAIL MODE	$E_n 13$	REAPPLY AC POWER
MAXIMUM RUN TIMER EXCEEDED AFTER AC POWER LOSS	$E_n 14$	BATTERY VOLTAGE MUST RISE ABOVE 24 VOLTS
MGT SUPERVISORY CONDITION (TAMPER, LOW BATTERY, MISSING HOURLY STATUS)	FAST BEEPS DURING PRESTART, FAST BEEP RUN ALARM, CHIRP EVERY 5 SECONDS AT IDLE	CLEARS WHEN MGT CONDITION CLEARS

## **Troubleshooting**

### **Contacting Technical Support**

For technical questions regarding Linear gate operators, contact the Technical Services Department at:

**1-800-421-1587 from 6:30 AM to 4:30 PM Pacific time**

### **Operator fails to start**

- A. Make sure you have power at the master distribution panel and that the power has not been turned off.
- B. If the “Reset to Factory Defaults” (CL) programming step has been used, ensure the motor type (MO) has been set to d2 and open (OC) and closed currents (CC) have been set.

### **Motor operates, but gate does not move**

- A. Make sure all mounting hardware is still attached and that all fasteners are tight.
- B. Check that the actuator worm gear is moving. If it isn't, the gears in the drive may have stripped.

### **Motor sounds like it is working harder than normal**

- A. Make sure the gate is moving freely and without binding throughout its entire travel.

### **Gate stopping part way open or closed (but no visible obstruction)**

- A. The Controller may have received a false obstruction input triggered by current sensing set too low. Make sure the gate moves freely through its entire travel before adjusting the current sensing.
- B. The Maximum Run Timer may have counted down and expired. This can be caused by having the timer set too low. When the timer expires, the gate stops and the beeper will sound.
- C. An obstruction signal from an accessory wired to the obstruction input may have triggered falsely. Check the control board for lit indicators for any of the following inputs: safety, shadow/reset, open obstruction, close obstruction, stop, etc. If any are lit when the operator should be running, remove all devices hooked to that function and hook them up one at a time and try to run the operator until the problem device is found. Refer to Page 8 for details on the control board indicators.

### **Gate staying open with automatic system**

- A. If there are vehicle detectors used with the operator, one of the loops or loop detectors may be sending a false signal or needs to be reset. Observe the indicators on the loop detector. Unplug the detector and try running the operator.
- B. An opening or reversing device may be stuck or malfunctioning. Try disconnecting these devices and hook them back up one at a time and try running the operator until the malfunctioning device is found.

### **How to Order Replacement Parts**

Use the part numbers listed on the following pages.  
Contact your local Linear dealer or distributor to order parts.

1. Supply the model number and serial number of your operator.
2. Specify the quantity of pieces needed and order by part number and name of part.
3. State whether to ship by freight, truck, parcel post, UPS or air express.
4. State whether transportation charges are to be prepaid or collect.
5. Specify name and address of person or company to whom parts are to be shipped.
6. Specify name and address of person or company to whom invoice is to be sent

# Model LRA Replacement Parts

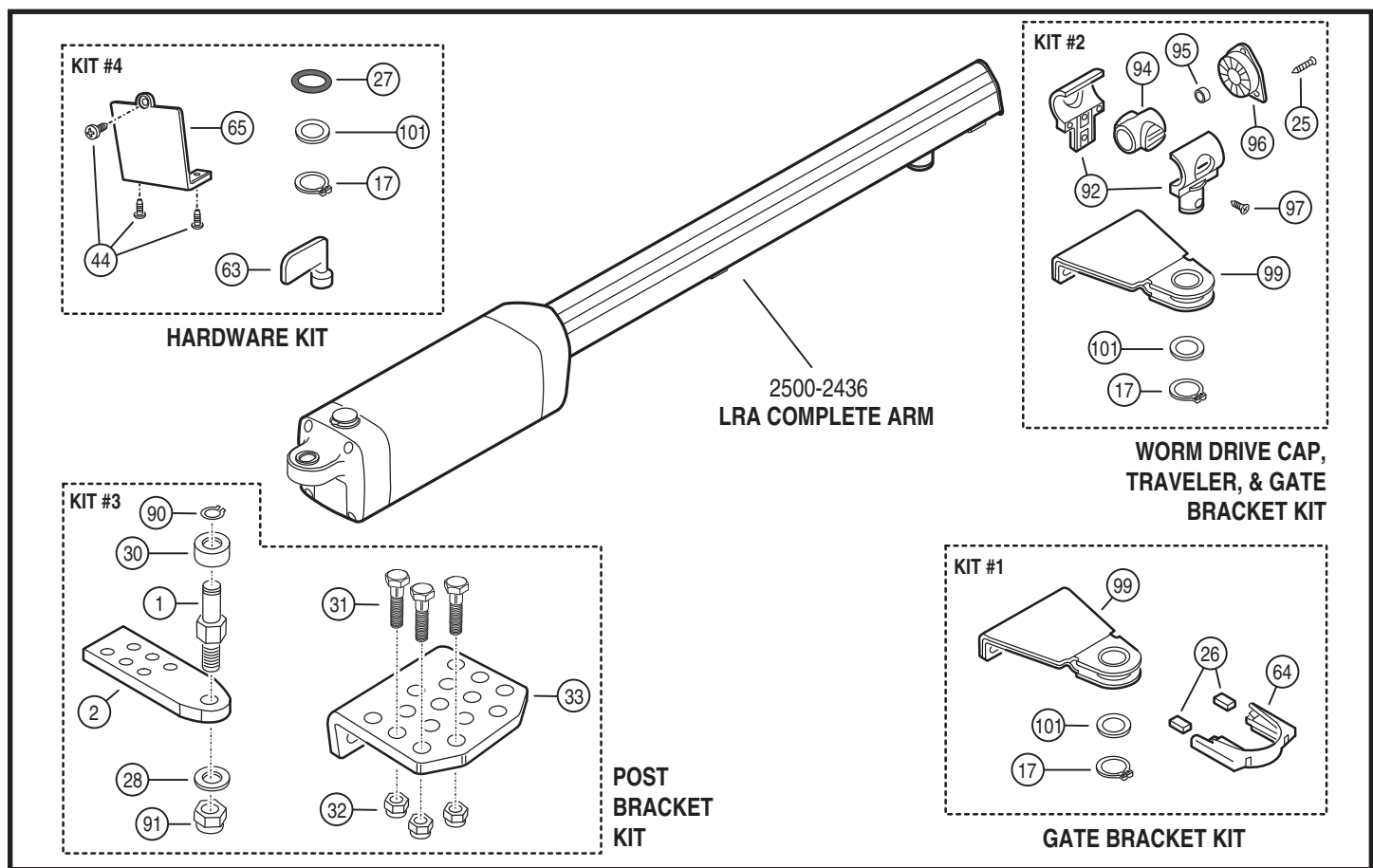

MODEL LRA ARM MECHANICAL PARTS LIST				
REF. #	PART #	ITEM #	REPLACEMENT PART	QTY.
KIT #1 Gate Bracket Kit	2500-2470	99	Gate Bracket	1
		64	Magnet Holder	1
		17	Seeger Ring D25	1
		101	Spacer	1
		26	Limit Magnet	2
KIT #2 Traveler, Cap, & Gate Bracket Kit	2500-2479	99	Gate Bracket	1
		96	Arm Cap	1
		94	Traveler	1
		97	Self-tapping Screw 4x18	2
		25	Self-tapping Screw 5x20	3
		17	Seeger Ring D25	1
		101	Spacer	1
		95	Self-lubricating Bushing	1
		92	Traveler Shell	2
		KIT #3 Post Bracket Kit	2500-2469	91
28	Washer			2
30	Bushing			30
90	Seeger Ring D12			1
2	Operator Bracket			1
1	Operator Bracket Pin			1
31	Bolt			3
32	Locknut			3
33	Post Bracket			1
KIT #4 Hardware Kit	2500-2478			65
		44	Self-Tapping Screw	3
		17	Seeger Ring D25	1
		101	Spacer	1
		27	O-ring	1
		63	Release Key	1
KIT #5 Limit Switch Kit	2510-461	29	Reed Sensor	1
		66	Sensor Cover	1
		21	Wire Holder	2
		7	Self-Tapping Screw	1
		63	2500-2471	Release Key Only
	2500-2436	Complete LRA Arm (w/o Controller)	1	

MODEL LRA CONTROLLER MECHANICAL PARTS LIST		
REF. #	PART #	DESCRIPTION
	2500-2474	Arm-to-Controller Cable, By Foot
	2100-2119	Apex LRA Mounting Plate
	2500-2472	Controller Enclosure (Complete w/o Apex Module)
	2500-2476	24 Volt Plug-in Transformer
	2520-518	Controller (Complete)
	2500-2511	Apex Dual Capable DC Motor Module

LRA2 DUAL GATE KIT		
REF. #	PART #	DESCRIPTION
	LRA2	Second LRA arm kit for dual-gate installations (kit includes one LRA arm, 40-feet of cable, and wiring strain-relief bushing)



## Preventative Maintenance



**Always disconnect power from operator before servicing.  
Keep clear of gate during operation.**

### General

Linear gate operators are designed for many years of trouble-free operation and, under recommended operating conditions, will require only minimal maintenance. To ensure that a unit is ready for operation at all times, and to preclude serious damage or failure, inspect the unit systematically. Proper adjustments and lubrication should be made as recommended.

### Lubrication

- ✓ **Motor** — Motors have sealed ball bearings and do not require further lubrication.
- ✓ **Post Bracket Pin & Traveler Shaft** — Lubricate the front and back pivot points with a lithium complex-based grease.
- ✓ **Actuator Body** — Wipe down the unit with a clean rag.
- ✓ **Control Cable** — Inspect the operator to control box cable for cracks in the insulation, breaks, or other signs of failure. Check all connection points. Replace cable if necessary.

### 6-Month Preventative Maintenance

1. Inspect all nuts and bolts for proper tightness and tighten as necessary.
2. Check all reversing devices for proper function. Inspect all contact edges for wear and replace if required. Check photoeyes for proper alignment and function.
3. Check current sensing for proper adjustment when finished with inspection and maintenance.
4. Inspect the installation area. Are all the warning signs intact and visible? If they are missing or need replaced, contact Linear. Be sure there are no control stations mounted within reach of the gate. Review safety literature with the customer and advise them to remove any such stations found.

### Battery Maintenance

The gel-cell batteries in this operator require no routine maintenance. For assured continued performance, they should be replaced every year. If power is to be removed for one week or more, disconnect the negative wire from the batteries as this will prevent deep discharging. Fully charge before use after storage or upon initial installation.

### FCC Notice

This device complies with FCC Rules Part 15 and Industry Canada Rules & Regulations. Operation is subject to the following two conditions: (1) This device may not cause harmful interference and (2) this device must accept any interference received, including interference that may cause undesired operation.

**For all gate operators, you must inspect the gate for proper operation. The gate should move easily without binding through its entire travel. If the gate does bind, adjust or fix as required. Failure to keep the gate in good working condition will have adverse effects on the operator.**

# Gate Operator Installation Checklist

---

INSTALLER    CUSTOMER

- |                          |                          |  |
|--------------------------|--------------------------|--|
| <input type="checkbox"/> | <input type="checkbox"/> | 1. The gate has been checked to make sure it is level and moves freely in both directions.   |
| <input type="checkbox"/> | <input type="checkbox"/> | 2. Potential pinch areas have been guarded so as to be inaccessible <b>OR</b> have contact and/or non-contact obstruction sensing devices installed.   |
| <input type="checkbox"/> | <input type="checkbox"/> | 3. The installer has installed one or more contact or non-contact obstruction sensing devices, in compliance with UL325 requirements for this installation.  |
| <input type="checkbox"/> | <input type="checkbox"/> | 4. If pedestrian traffic is expected, a separate pedestrian gate has been installed, a minimum of seven feet from the gate. The customer has been informed that <u>all pedestrian traffic must use the pedestrian gate.</u>  |
| <input type="checkbox"/> | <input type="checkbox"/> | 5. Warning signs have been installed on each side of the gate in highly visible locations. The customer has been informed that these signs must remain at all times.   |
| <input type="checkbox"/> | <input type="checkbox"/> | 6. There are no controls installed on the gate operator, or within seven feet of the gate.   |
| <input type="checkbox"/> | <input type="checkbox"/> | 7. The installer has properly adjusted the obstruction sensing feature and has tested the gate to make sure that the gate stops and reverses a short distance with minimal resistance applied (40 lbs. on a swing gate at the end of the gate, 75 lbs. on a slide gate)                |
| <input type="checkbox"/> | <input type="checkbox"/> | 8. The installer has instructed the customer in the proper use of the gate operator and reviewed all of the operational functions, obstruction sensing devices, warning beeper and reset, etc.   |
| <input type="checkbox"/> | <input type="checkbox"/> | 9. The installer has instructed the customer in the proper use of the operator's manual disconnect feature. The manual disconnect must never be used while the gate is in motion. The power switch must be turned off before using the manual disconnect and disengaging the operator. |
| <input type="checkbox"/> | <input type="checkbox"/> | 10. The installer has reviewed all safety instructions with the customer, and has left the safety instructions and owner's information sheets for their reference.   |
| <input type="checkbox"/> | <input type="checkbox"/> | 11. The installer has answered any questions the customer has regarding the operation of the gate operator and gate operator safety precautions.   |
| <input type="checkbox"/> | <input type="checkbox"/> | 12. The installer has explained to the customer that a regular maintenance schedule for both the gate and the gate operator is recommended.  |

By signing this installation checklist, I/we hereby certify that each item listed and checked above has been covered by the installer and is clearly understood by the customer.

\_\_\_\_\_  
Customer's Signature

\_\_\_\_\_  
Date

\_\_\_\_\_  
Installer's Signature

\_\_\_\_\_  
Date