

Linear ACCESS

RE-1

Residential Telephone Entry System

With Built-in Wireless Receiver

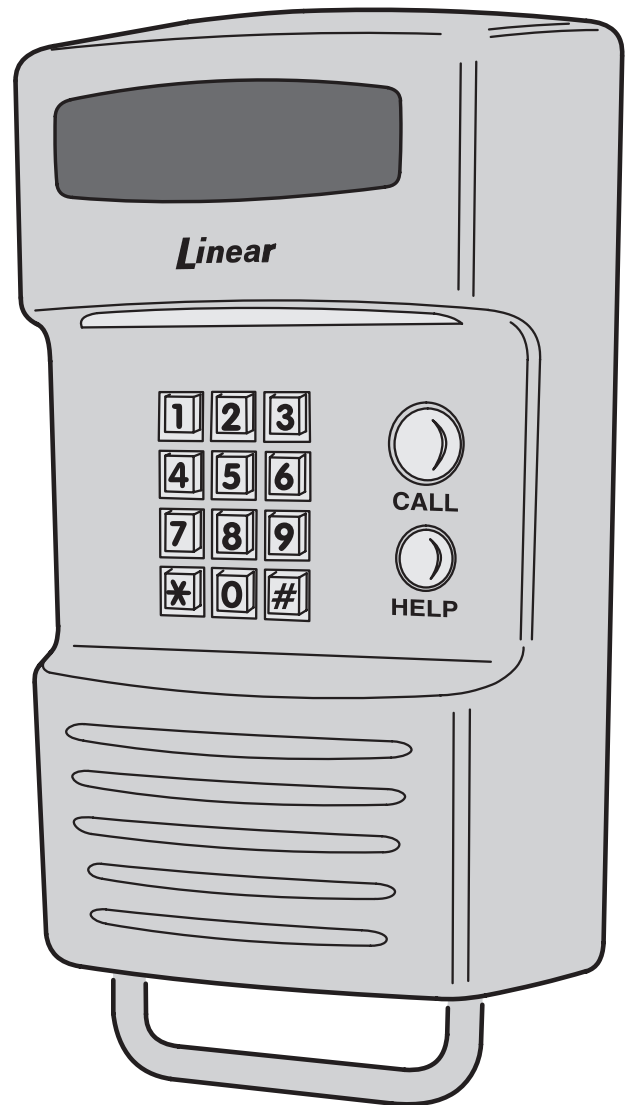

***Installation,
Programming,
and Operation Instructions***

Linear[®]

(760) 438-7000 • FAX (760) 438-7043
USA & Canada (800) 421-1587 & (800) 392-0123
Toll Free FAX (800) 468-1340
www.linearcorp.com

CONTENTS

PRODUCT DESCRIPTION	1
INSTALLATION INFORMATION	2
COMPONENT LOCATIONS	3
WIRING DIAGRAM	4
ENTRY SYSTEM MOUNTING	5
TELEPHONE WIRING	5
TELEPHONE WIRING OPTIONS	6
CONTROL WIRING	7
POWER, BATTERY, & GROUND WIRING	8
OPTIONAL REMOTE KEYPAD	8
OPTIONAL KEYSWITCH	9
OPTIONAL CCTV CAMERA	10
PROGRAMMING REFERENCE	11
PROGRAMMING ACCESS	12
BASIC SYSTEM PROGRAMMING	13
ENTRY CODE PROGRAMMING	14
TRANSMITTER PROGRAMMING	14
TELEPHONE PROGRAMMING	15
ADVANCED SYSTEM PROGRAMMING	16
SYSTEM ADJUSTMENTS	17
RE-1 OPERATION	18
RESIDENT PROGRAMMING QUICK REFERENCE	19
SPECIFICATIONS	20
DIMENSION DRAWING	20
TROUBLESHOOTING	20
PROGRAMMING WORKSHEET	21
LINEAR LIMITED WARRANTY	25

FEATURES

- **TWO-WAY SPEAKERPHONE**
- **CALL WAITING**
- **CALL FORWARDING**
- **DISTINCTIVE RINGS FOR ACCESS CALLS**
- **SEVEN ACCESS TIME ZONES**
- **TIMED “DO NOT DISTURB” PRIVACY FEATURE**
- **DIGITALLY SYNTHESIZED HUMAN VOICE PROMPTS**
- **RESIDENCE CONTROL OF RELAYS**
- **PROGRAMMABLE RELAY CONTROL PREFIXES**
- **100 ENTRY CODE CAPACITY**
- **1-6 DIGIT ENTRY CODE LENGTH**
- **EACH ENTRY CODE CAN BE PROGRAMMED TO ACTIVATE EITHER OR BOTH RELAYS**
- **100 TRANSMITTER CAPACITY**
- **SUPPORTS 4 BLOCKS OF TRANSMITTERS WITH 24 FACILITY CODES**
- **UP TO FOUR ACCESS GROUPS FOR SHARED CONTROL OF TRANSMITTER BLOCKS**
- **SUPPORTS MGT SAFETY EDGE TRANSMITTER**
- **INTERNAL CLOCK AND CALENDAR WITH BATTERY BACKUP**
- **EVENT LOG MEMORY RETAINS THE LAST 450 SYSTEM EVENTS**
- **KEYPAD PROGRAMMABLE**
- **LOCALLY & REMOTELY PROGRAMMABLE WITH A TELEPHONE OR COMPUTER**
- **PROGRAMMING SOFTWARE BUILT-IN, CONNECT WITH ANY INTERNET BROWSER**
- **WEATHER-PROOF, TAMPER-RESISTANT HOUSING**
- **SUPERHETERODYNE RADIO RECEIVER**
- **INTEGRAL RADIO ANTENNA**
- **REMOTE KEYPAD SUPPORT**
- **BRIGHT WHITE LED DOWNLIGHT**
- **PIEZO SOUNDER**
- **2 HEAVY DUTY FORM “C” (N.O. & N.C) RELAY OUTPUTS**
- **TIMED ANTI-PASSBACK**
- **KEYPAD LOCKOUT**
- **TACTILE KEY FEEL**
- **TWO DOOR SENSE/INHIBIT INPUTS**
- **TWO OPEN REQUEST INPUTS**
- **ACCESS KEYSWITCH PROVISION**
- **REMOVABLE TERMINAL BLOCKS**
- **OPTIONAL CCTV CAMERA WITH INFRARED ILLUMINATORS**

PRODUCT DESCRIPTION

Linear's RE-1 Telephone Entry System is designed for residential or light commercial access control applications. The speakerphone, keypad, radio receiver, and optional video camera are housed in a rugged enclosure that can be mounted to a pedestal or bolted directly to a wall. The die-cast keypad keys have bright, easy-to-read graphics and are lit with an overhead light. The two operation buttons; **CALL** and **HELP**, are machined for heavy-duty reliability.

Operation

Arriving visitors will approach the unit and place a call to the residence by pressing the **CALL** button. The RE-1 will acquire the residence's local telephone line and generate distinctive rings to the house telephones. The resident, knowing that the distinctive ring is originating from the access area, can answer any house telephone and converse with the visitor. If the resident decides to grant access to the visitor, they can activate either output relay in the RE-1 by pressing a key on the telephone's keypad. If the resident decides not to grant access, hanging up or pressing a key will disconnect the visitor's call.

Call Waiting

If the resident is using the telephone at the time a visitor calls, the RE-1 will sound beeps on the telephone line to announce that a visitor is calling. The resident can press a key on the telephone to place the outside caller on hold and communicate with the visitor. After granting or denying access to the visitor, the outside caller will be re-connected to the resident.

Call Forwarding

Programmable call forwarding allows the RE-1 to dial any selected telephone number when a visitor presses the **CALL** button. For example, with call forwarding enabled, the RE-1 could dial a cell phone to contact the resident while outside or away from the residence. The resident will be able to communicate with the visitor and grant or deny access from the remote telephone.

Alternate Numbers

For installations where multiple residences exist inside the same controlled opening (such as a guest house or granny flat) three alternate calling numbers can be programmed. The alternate numbers can be called by entering a short code at the keypad.

Local Control

The resident can issue control commands from the local telephones without a call from a visitor. By dialing a specific series of digits, the resident can control either of the two relays. The resident can also initiate voice communications with the entry system.

Access Media

Up to 100 entry codes, from 1 to 6 digits in length, can be programmed. Each entry code can activate either, or both, of the relay outputs. Linear's Model AM-KP keypad can be used as a secondary remote keypad for the RE-1.

Up to four sets of block coded MegaCode® transmitters (up to 60 transmitters total) can be used to gain access through the RE-1's built-in radio receiver. Each transmitter can be individually suspended or re-activated. Four facility codes can be programmed to identify each block of transmitters. **Programming of individual (non-block coded) transmitters is not supported by the RE-1.**

System Features

Time Zones

The RE-1 contains an internal clock and calendar. Seven programmable "time zones" allow setting time periods to schedule system functions. Each time zone can be active or inactive on certain days. Keypad entry codes, wireless transmitters, automatic access control, call forwarding, and the "Do Not Disturb" feature can each be set to only be active during a specific time zone period. Up to ten "holiday" days can be programmed. Each of the seven time zones can be set to be active or inactive during a holiday.

Portal Supervision

The **SENSE/INHIBIT** input can be used two ways. If programmed for "door sense", a switch on the door detects forced entry or door ajar situations. If programmed for "inhibit", the input can be wired to a "service" switch or automatic timer that will disable the Relay #1 when required.

Hardwired Activation

The **OPEN REQUEST** input can be wired to an exit loop detector or exit photo beam to allow automatic exit activation. An emergency access keyswitch can be mounted in the RE-1 case to allow keyed entry for authorized personnel.

Access Security

The "anti-passback" feature allows the option of preventing the use of the same code or the same transmitter again before the programmed time elapses. The "keypad lockout" feature discourages tampering by disabling the keypad for three minutes after a programmable number of incorrect entry codes has been entered at the keypad.

Event Log

An access log of up to 450 events is stored in the unit's memory. System activity is logged as it occurs with the date and time of the event. The access log data can be retrieved locally or remotely with a computer through the RE-1's built-in modem.

Local & Remote Programming

The system's built-in programming software can be accessed on-site or off-site using a computer with any Internet browser. The software's graphic display of each of the programming step makes programming easy. Without a computer, the RE-1 can be programmed with its main keypad, from any local telephone connected to the same line, or by calling from any remote telephone.

The EEPROM memory retains all entry codes, transmitter information, and programming, even without power.

Obstacle Detection

Linear's Model MGT safety edge transmitter is compatible with the RE-1. This MGT detects and transmits obstacle events to the RE-1 receiver. Obstacle signals from an MGT transmitter will activate Relay #2.

Alarm Interface

Relay #2 can be programmed for *alarm shunt* to bypass an alarm loop during entry, or *alarm trigger* to cause an alarm during forced entry. Five other activation options are available for Relay #2.

Voice Synthesizer

A built-in voice synthesizer sounds voice prompts through the speaker, local and remote telephones.

INSTALLATION INFORMATION

Before beginning installation, please review the entire instructions and become familiar with the system's operation, wiring, and programmable options.

System Location

For pedestrian door or gate installations, mount the Entry System on a rigid wall near the controlled door. Avoid mounting the unit in a location where regular mechanical shock will occur due to a slamming door or spring loaded pedestrian gate.

For vehicular gate installations, mount the Entry System in clear view of the gate, but far enough from the gate so the user cannot touch the gate from the keypad.



- ★ **WARNING FOR ALL GATE INSTALLATIONS: TO AVOID SERIOUS INJURY OR DEATH, MAKE SURE THAT THE UNIT IS FAR ENOUGH FROM THE GATE SO THAT THE USER CANNOT TOUCH THE GATE WHILE OPERATING THE KEYPAD. HOWEVER, FOR SAFETY, THE GATE MUST BE FULLY VISIBLE FROM THE KEYPAD.**

Telephone Wires

The quality of the system's audio communications is related to the type of telephone wire and its installation. Noise and hum can be introduced into the telephone wires. Use only high-quality telephone wire rated for direct underground burial. All telephone wire should be twisted-pair.

- Minimum size of 24 AWG for up to 800 feet.
- Minimum size of 22 AWG for up to 1600 feet.
- Minimum size of 20 AWG for up to 2200 feet.
- Minimum size of 18 AWG for up to 3600 feet.

DO NOT ROUTE TELEPHONE AND AC WIRING INSIDE THE SAME CONDUIT. Route all telephone wires inside a dedicated conduit that is at least six inches away from any AC line wiring.

Power Supply

Use the supplied 16-volt 20-VA transformer to power the RE-1. **DO NOT POWER ANY OTHER EQUIPMENT FROM THE SAME TRANSFORMER,** use a separate power supply. Keep the system power wires as short as practical to reduce the chance of noise and hum pickup.

- For low voltage power wire runs up to 100 feet, use 18 AWG, THHN 600-volt insulated wire.
- For low voltage power wire runs up to 200 feet, use 16 AWG, THHN 600-volt insulated wire.
- Use 22 AWG or larger (depending on the load) for all other connections.

ALWAYS REMOVE POWER PRIOR TO SERVICING

Earth Ground

To avoid damage to the unit from static discharges, connect the RE-1's **EARTH GROUND** and case ground terminals to a good earth grounding point within 10 feet. The case ground terminal is the #8 screw located on the backplate above the wire entry hole. Also, the RE-1's Telephone Bypass Module must be grounded to provide surge protection for the telephone line. Suggested wiring size is 12 AWG for earth ground.

COMPONENT LOCATIONS

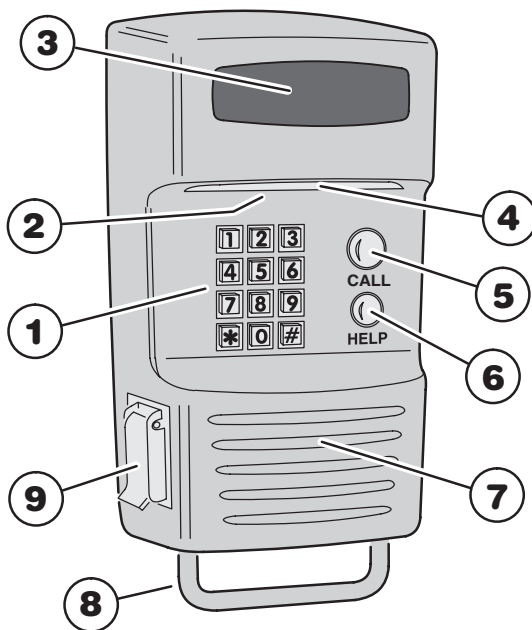

1 **KEYPAD**

Die-cast metal 12-key keypad with tactile action. For system programming and keying in entry codes.

2 **DOWNLIGHT**

Illuminates keypad and visitor operation buttons. The light operates dusk to dawn and adjusts its time depending on the system's geographic location.

3 **OPTIONAL CCTV CAMERA**

Location for the optional Model RE-BWC CCTV camera. The camera views the keypad area and has infrared lighting for nighttime use.

4 **MICROPHONE**

The high-sensitivity microphone monitors sound at the keypad area for the entry system's speakerphone.

5 **CALL BUTTON**

Pressing this button causes the system to call the residence telephones with a distinctive ring signal.

6 **HELP BUTTON**

Pressing this button causes the system to play the help message to instruct the visitor on system use.

7 **SPEAKER**

Weatherproof speaker for system operation and programming.

8 **INTEGRAL ANTENNA**

Hidden antenna receives wireless radio signals from transmitters.

9 **OPTIONAL KEYLOCK**

Location for mounting access keylock. (MEDECO keylock with stainless steel cover shown).

10 **MAIN TERMINAL BLOCK**

For power, backup battery, sense inputs, open request inputs, and remote keypad connections.

11 **SPEAKERPHONE VOLUME CONTROL**

Controls the audio level produced by the speaker during communications between the visitor and the resident.

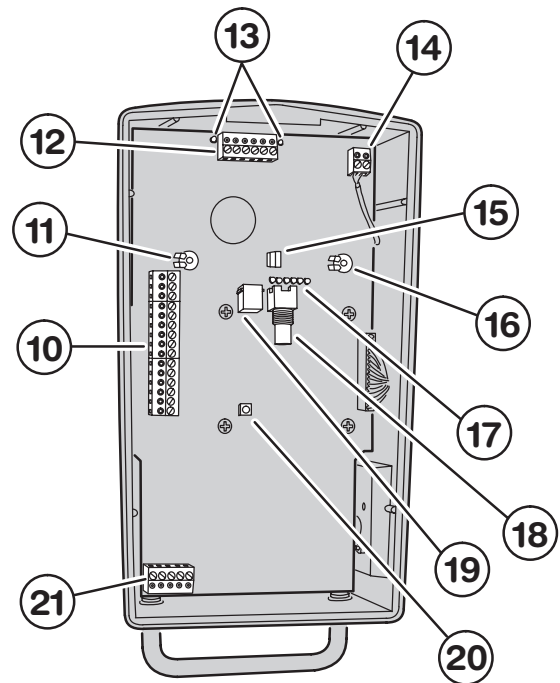

12 **RELAY TERMINAL BLOCK**

For Relay #1 and Relay #2 output connections to the access control devices.

13 **RELAY INDICATORS**

Indicators for Relay #1 and Relay #2 will light when the relay is activated.

14 **ANTENNA TERMINAL BLOCK**

For shield and center conductor connection of the coax cable from the system's built-in radio antenna.

15 **LINE MONITOR JUMPER**

For testing and troubleshooting. Remove jumper to listen to telephone line audio through the speaker.

16 **DIGITAL SPEECH VOLUME CONTROL**

Controls the audio level of the voice synthesizer. This adjustment effects the audio level of the voice synthesizer and system tone from the speaker.

17 **STATUS INDICATORS**

Six indicators light to display system power, radio, and modem status.

18 **VIDEO CONNECTOR**

For cable connection to a video monitor. (Optional Model RE-BWC CCTV camera required).

19 **CAMERA CONNECTOR**

Provides power and video connection for the optional Model RE-BWC CCTV camera.

20 **RESTART BUTTON**

Pressing this button restarts the system. This button DOES NOT erase any programming data.

21 **TELEPHONE TERMINAL BLOCK**

For telephone line and earth ground connections.

WIRING DIAGRAM

TYPICAL GATE INSTALLATION WIRING

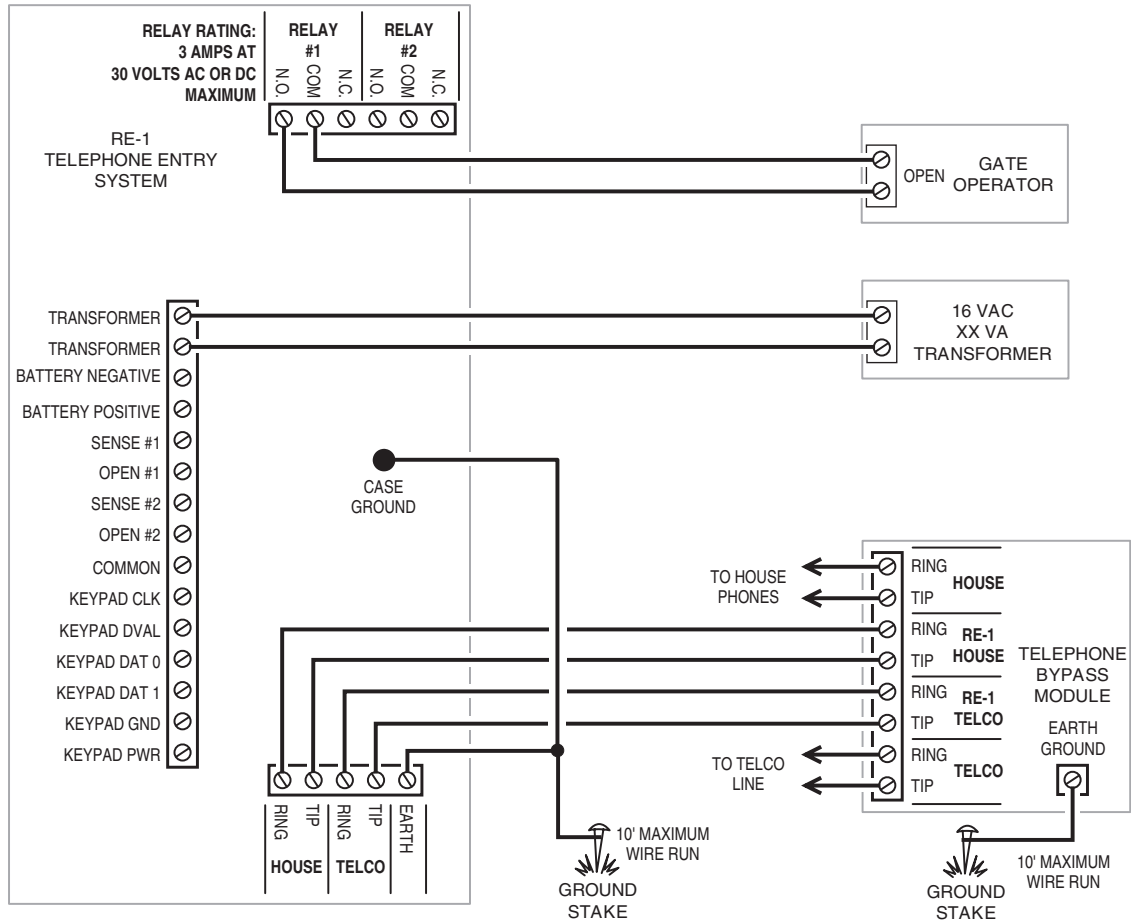

TYPICAL DOOR INSTALLATION WIRING

NOTE: A MAGNETIC LOCK AND DOOR STRIKE ARE BOTH SHOWN, TYPICALLY ONLY ONE IS USED

NOTE: DO NOT POWER THE LOCKING DEVICE FROM THE RE-1 TRANSFORMER

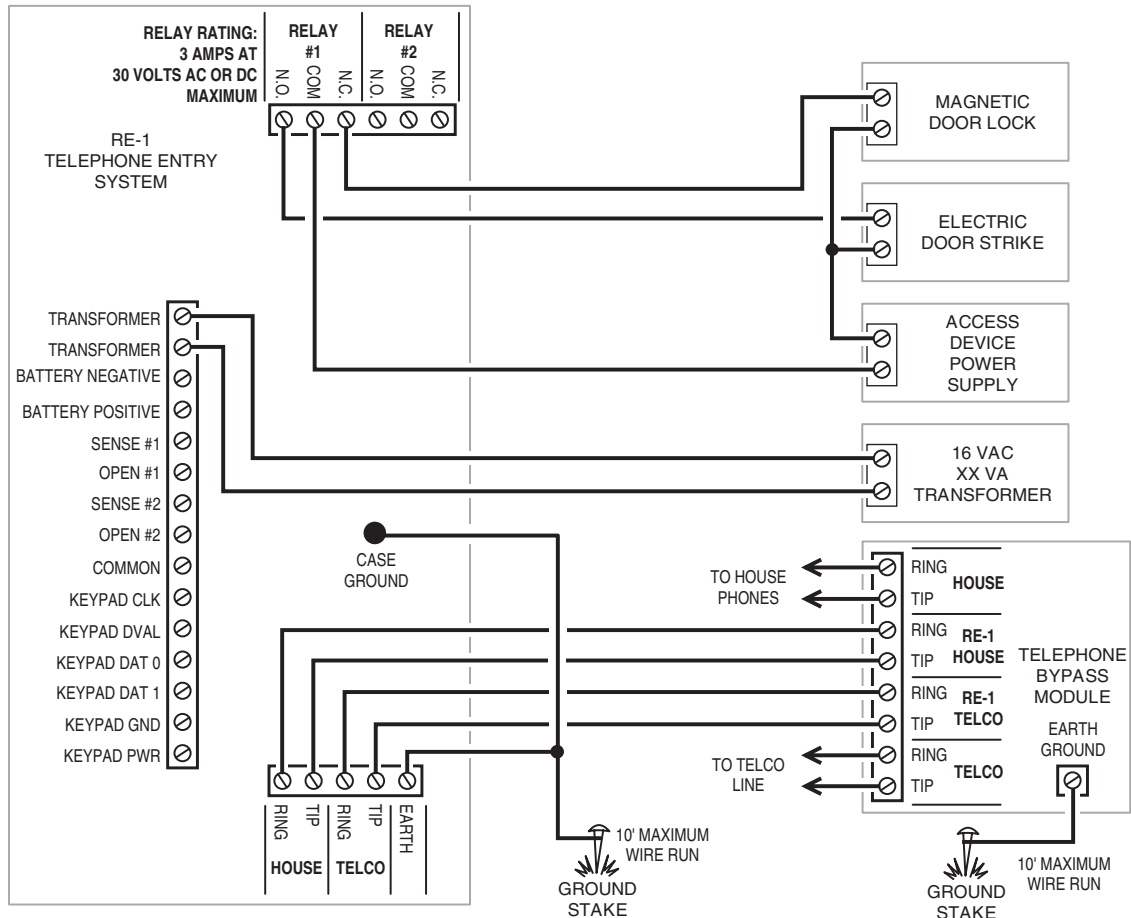

ENTRY SYSTEM MOUNTING

Pedestal Mounting

The RE-1 Entry System can be mounted on a standard pedestal.

1. Open the RE-1 case by removing the two security screws with the wrench provided (see Figure 1).
2. Use four security bolts and locking nuts to secure the backplate to the pedestal (see Figure 2).

Wall Mounting

The RE-1 Entry System can be mounted directly to a wall or flat surface.

1. Open the RE-1 case by removing the two security screws with the wrench provided (see Figure 1).
2. Use the appropriate fasteners to secure the system's backplate to the mounting surface. When mounting the system to a concrete wall, use concrete wedge anchors (see Figure 3).

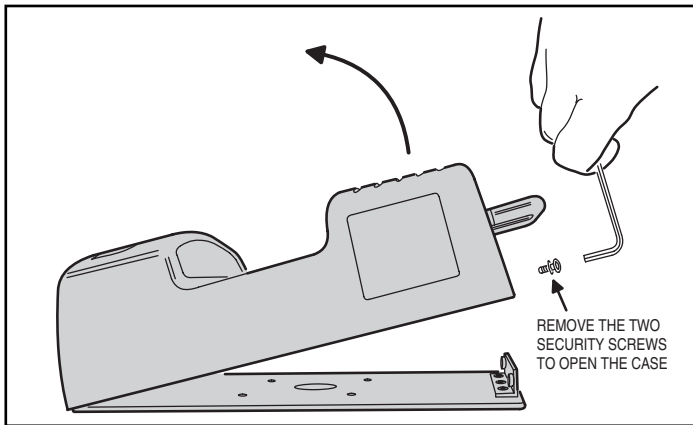

Figure 1. Opening the RE-1 Case

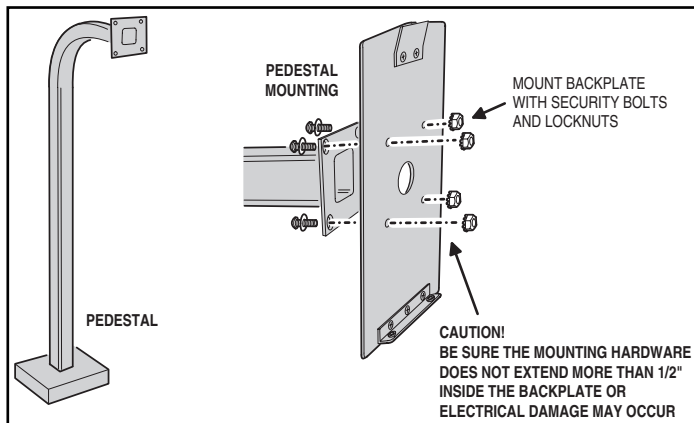

Figure 2. Pedestal Mounting Backplate

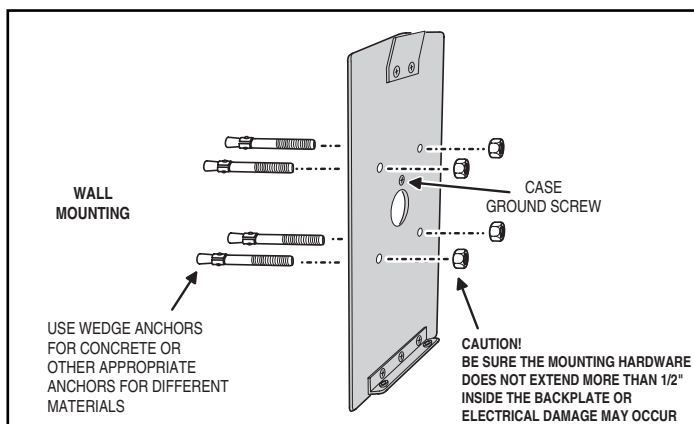

Figure 3. Wall Mounting Backplate

TELEPHONE WIRING

The RE-1 connects between the incoming telephone line of the residence and local telephone sets.

Telephone Bypass Module

The RE-1's Telephone Bypass Module provides a switch to remove the RE-1 from the telephone line and re-connect the local telephones to the telephone system. **ALL TELEPHONE WIRING FOR THE RE-1 MUST PASS THROUGH THE BYPASS MODULE.**

The bypass module is housed in a weather-resistant enclosure and should be located in an area that is easily accessible to the resident. In case of system trouble, the resident can use the bypass switch to remove the RE-1 from the telephone system.

Telephone Wiring

- **DO NOT ROUTE TELEPHONE AND AC WIRING INSIDE THE SAME CONDUIT.** Route all telephone wires inside a dedicated conduit that is at least six inches away from any AC line wiring.
- All telephone wiring must be made on the "house" side of the telephone company's demarcation device (the terminal block where the telephone line connects to the residence).
- If any security system or personal alert system at the residence is connected to the telephone line, be sure that it is connected to the line ahead of the Telephone Bypass Module using a RJ-31X or RJ-38X interface.
- Use only high-quality telephone wire rated for direct underground burial. All telephone wire should be twisted-pair with a minimum size of 24 AWG.

Typical Telephone Wiring

1. Connect the bypass module's **EARTH GROUND** terminal to a good earth ground.
2. Before connecting the incoming telephone line to the bypass module check the polarity of the wires with a DC voltmeter. Connect the negative wire (**RING** - usually green) to the bypass module **TELCO RING** terminal. Connect the positive wire (**TIP** - usually red) to the bypass module **TELCO TIP** terminal.
3. Connect the resident's local telephone line **RING** (usually green) to the bypass module **HOUSE RING**. Connect the local telephone line **TIP** (usually red) to the bypass module **HOUSE TIP** terminal.
4. Connect the RE-1 **TELCO RING** to the bypass module **RE-1 TELCO RING** terminal. Connect the RE-1 **TELCO TIP** to the bypass module **RE-1 TELCO TIP** terminal.
5. Connect the RE-1 **HOUSE RING** to the bypass module **RE-1 HOUSE RING** terminal. Connect the RE-1 **HOUSE TIP** to the bypass module **RE-1 HOUSE TIP** terminal.

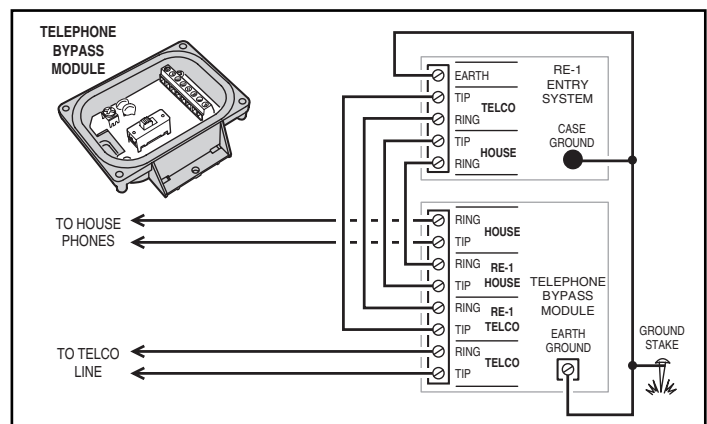

Figure 4. Telephone Wiring

TELEPHONE WIRING OPTIONS

Shared Line

This is the standard configuration. The telephone line is routed through the RE-1 to the house phones. Pressing the Call button on the RE-1 will cause the RE-1 to disconnect the house phones from the telephone company line and generate a ring signal that is heard on the house phones.

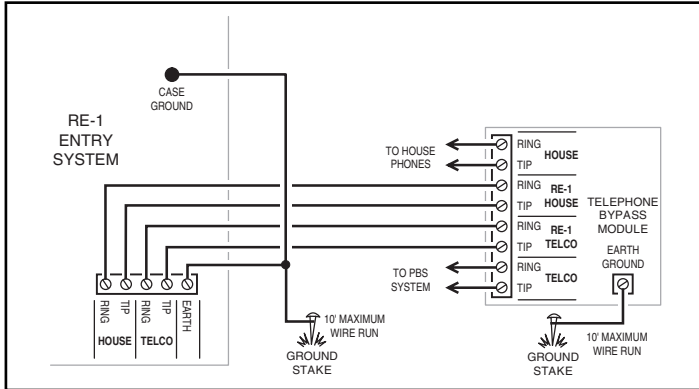

Figure 5. Shared Line Wiring

Dedicated Line

Pressing the Call button on the RE-1 will cause the RE-1 to seize the phone line and dial out to an outside number.

See PPN #54 for programming options.

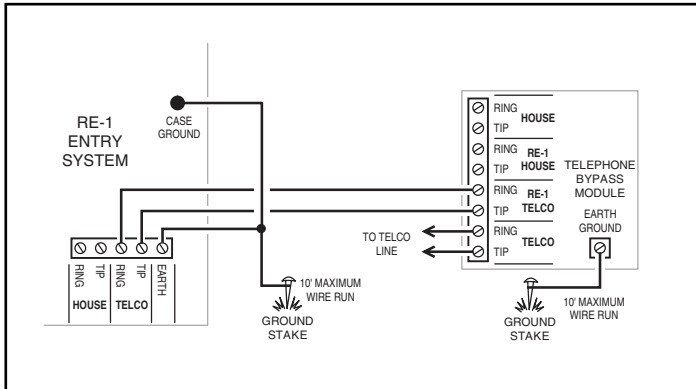

Figure 6. Dedicated Line Wiring

Intercom Mode

Pressing the Call button on the RE-1 will cause the RE-1 to generate a ring signal as if it were an intercom station. A live phone line is not used and the RE-1 provides power for the remote intercom phone.

- ◆ **Note:** in this mode, remote programming, call forwarding or alternate resident calling is not available.

See PPN #52 for programming options.

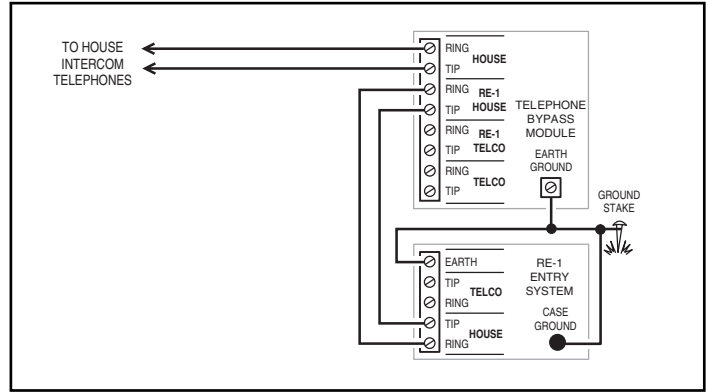

Figure 7. Intercom Mode Wiring

Ring Down Mode

Pressing the Call button on the RE-1 will cause the RE-1 to seize the phone line and provide immediate communications with the PBX system

See PPN #54 for programming options.

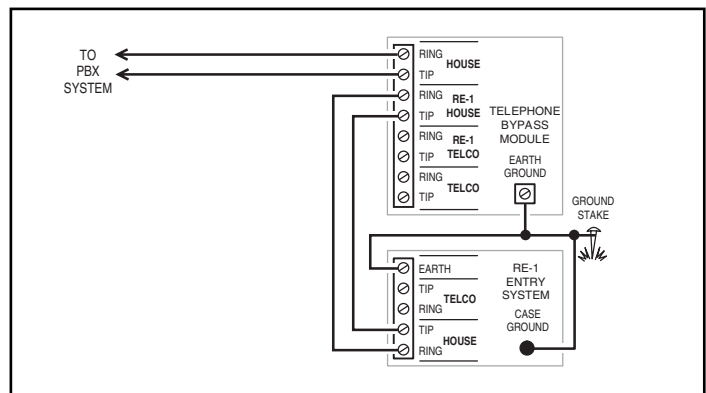

Figure 8. Ring Down Mode Wiring

CONTROL WIRING

Gate Control

- Route two wires between the gate and the RE-1. Connect the gate operator's **OPEN** terminals to the RE-1 Relay #1 **COM & N.O.** terminals.
 - NOTE:** For operator wiring specifics, refer to the gate operator's wiring diagram.
- If an access keyswitch is required refer to the Optional Keyswitch section of this manual for details on keyswitch wiring and installation.
- If an external timer for preventing access at certain times is required, route two wires from the RE-1 to the timer contacts. Connect the timer contacts to the RE-1 **SENSE #1** and **COMMON** terminals.
 - NOTE:** If the sense input is going to be used as an inhibit input, it must be programmed to select that input type. See programming PPN #29.

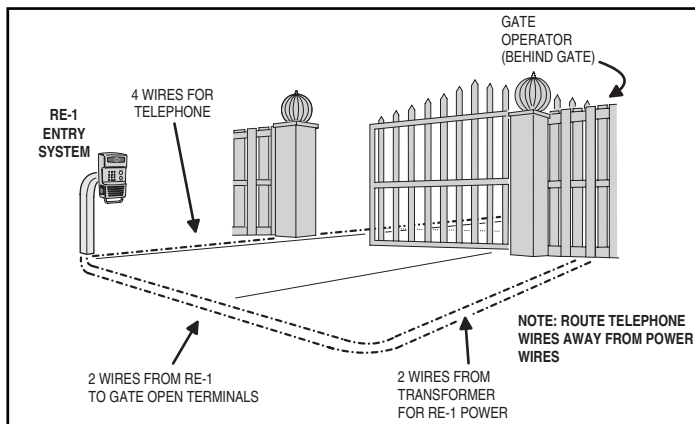

Figure 9. Gate Installation Example

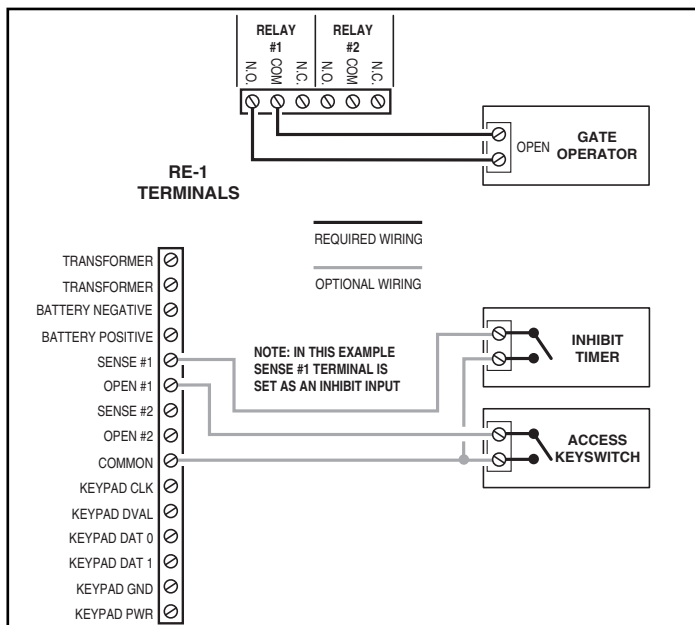

Figure 10. Gate Installation Wiring

Door or Pedestrian Gate Control

- Install a low voltage electric door strike or magnetic lock as a locking device for the door or pedestrian gate.
- Install the power supply or transformer for the locking device. **DO NOT POWER THE RE-1 FROM THIS POWER SUPPLY.**
- Connect one wire from the power supply to one wire from the locking device.
- Route two wires between the locking device and the RE-1. Connect one wire to the remaining wire of the locking device. Connect the other wire to the remaining wire of the power supply.
 - For a door strike, connect the wires to the RE-1 Relay #1 **COM & N.O.** terminals.
 - For a magnetic lock, connect the wires to the RE-1 Relay #1 **COM & N.C.** terminals.
- If an access keyswitch is required refer to the Optional Keyswitch section of this manual for details on keyswitch wiring and installation.
- To use the door sense feature to detect forced entry or door ajar conditions, install a normally closed door switch on the door or pedestrian gate and route two wires from the switch to the RE-1. Connect the door sense switch to the RE-1 **SENSE #1** and **COMMON** terminals. See programming PPN #24 & #27 to define when Relay #2 will activate based on the sense input.

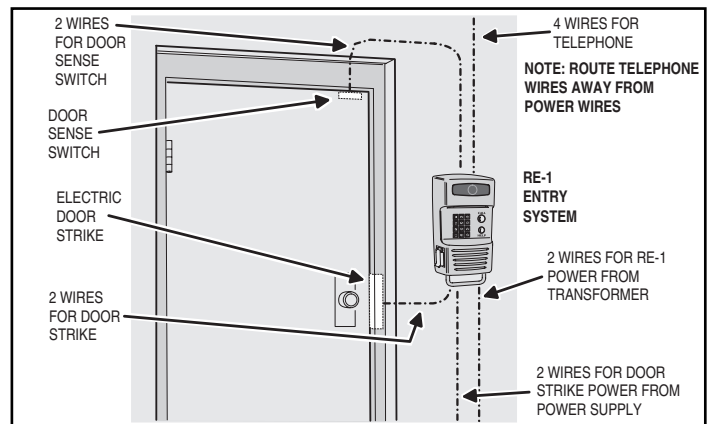

Figure 11. Door Installation Example

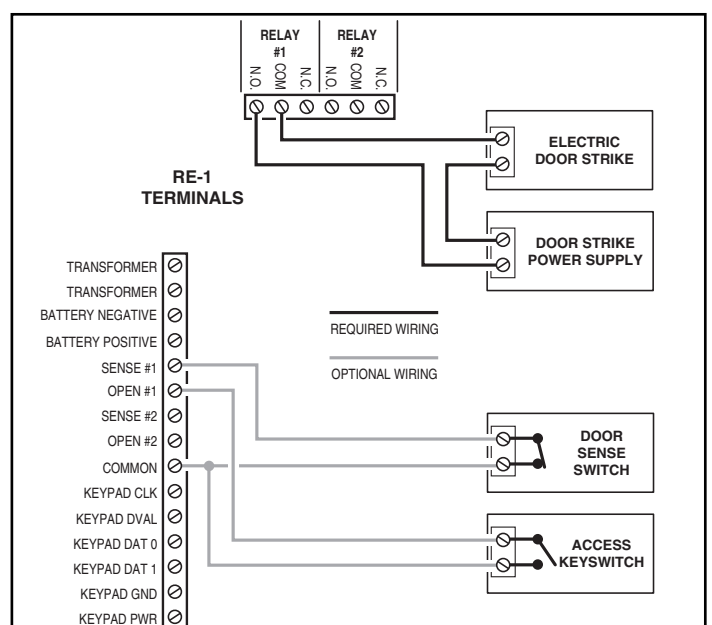

Figure 12. Door Installation Wiring

POWER, BATTERY, & GROUND WIRING

Power Wiring

◆ **NOTE: DO NOT APPLY POWER UNTIL THE INSTALLATION IS COMPLETE.**

- Route two wires between the RE-1 and the power transformer.
 - For power wire runs up to 100 feet, use 18 AWG, THHN 600-volt insulated wire.
 - For power wire runs up to 200 feet, use 16 AWG, THHN 600-volt insulated wire.
- Connect the wires to the transformer. Connect the other end of the wires to the two RE-1 **TRANSFORMER** terminals.

Backup Battery

Use of battery backup is optional. It will allow the RE-1 to operate for short periods of time without AC power. Two 12-volt backup batteries in series are recommended to obtain the proper working voltage for the RE-1. A single 12-volt battery can be used, although the call waiting beeps and the ring voltage will be lower than normal when five telephones are connected. The door or gate access device must use some type of battery backup for the entire system to be functional.

Backup batteries will not fit into the RE-1 housing. Protect the backup batteries inside a rain-tight NEMA enclosure suitable for the installation.

◆ **NOTE: Backup batteries are not required to maintain the RE-1 clock/calendar and programming memory during power outages.**

- Route two wires between the RE-1 and the backup batteries.
- Connect two 1.2 Amp/hour (minimum), 12-volt, gel cell batteries in series (Battery #1 negative to Battery #2 positive).
- Connect the Battery #1 positive to the RE-1 **BATTERY POSITIVE** terminal.
- Connect the Battery #2 negative to the RE-1 **BATTERY NEGATIVE** terminal.

◆ **NOTE: The RE-1 does not supply battery charging current. An external battery charger will be required to maintain the batteries.**

Earth Ground

For the best ground, use size 12 gauge solid wire or larger to connect the to an 8-foot copper ground rod. Locate the ground rod next to the Power and Telephone company rods and bond the rods together with a new clamp. Do not disturb the clamps installed by the Power or Telephone Company. Alternately, connect to a cold water pipe for the earth ground.

- Connect the RE-1 **EARTH** terminal to the earth ground wire.
- Connect the Telephone Bypass Module **EARTH GROUND** terminal to the earth ground wire.

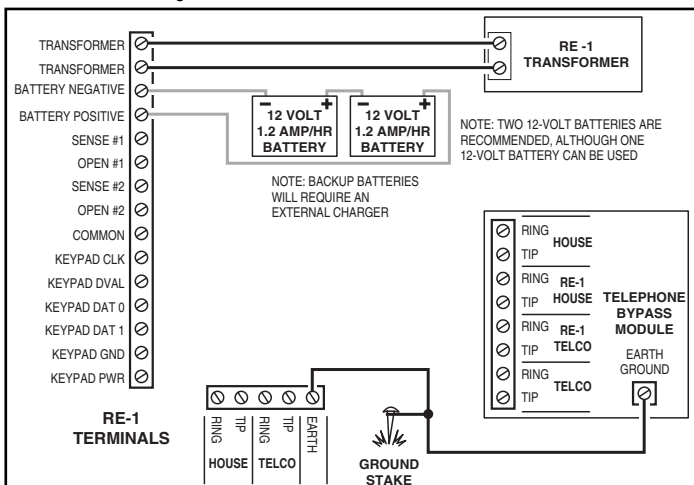

Figure 13. Power, Backup Battery & Ground Wiring

OPTIONAL REMOTE KEYPAD

The optional Model AM-KP remote keypad can be used with the RE-1 entry system. A typical application for the remote keypad would be to control a second door or gate. Entry codes are the only method of access allowed at a remote keypad. The default system setting will cause the remote keypad to activate Relay #2.

- Mount the AM-KP keypad onto a pedestal or to a wall.
- Route 6-conductor cable from the RE-1 to the AM-KP.
 - For wire runs up to 300 feet use 24 AWG Belden Type 9931 or equivalent.
 - For wire runs up to 600 feet use 20 AWG Weico Type 9405 or equivalent.
- Set the **DEVICE ADDRESS** rotary switch in the AM-KP to match the remote keypad address in the RE-1 (default = 3).
- Connect the 6-conductor cable as shown in Figure 11.
- Secure and lock the AM-KP to its mounting plate.

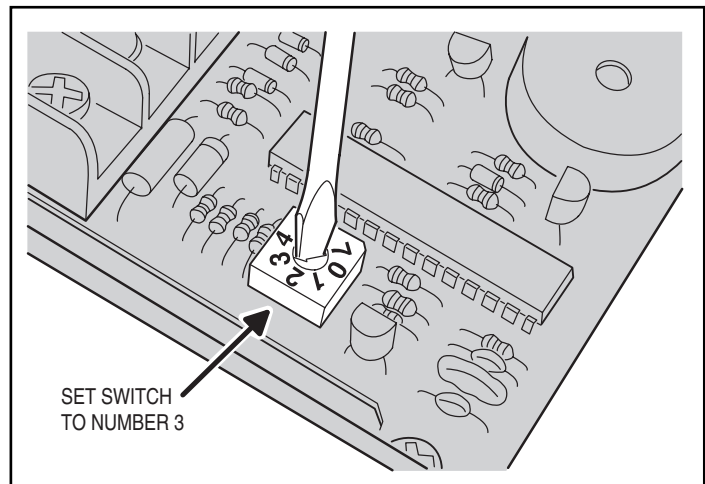

Figure 14. Setting the Keypad Device Address

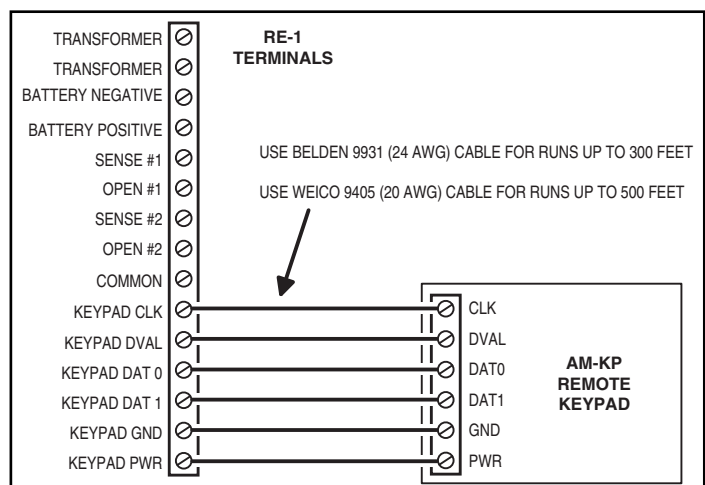

Figure 15. Remote Keypad Wiring

OPTIONAL KEYSWITCH

A keyswitch can be installed in the RE-1 Entry System to provide keyed access. The RE-1 case is designed to accept a Medco Model KS-M keyswitch.

Keyswitch Installation

1. Disconnect the wiring harness connector and remove the antenna terminal block. Remove the four circuit board retaining screws and the RE-1 circuit board (see Figure 16).
2. Remove the screw and washer that retain the keyswitch hole access plate (see Figure 17).
3. Hold the lock cover and plastic spacer in place on the RE-1 case. Secure the assembly with four screws, lock washers, and nuts. Slide the keyswitch into the hole, oriented as shown (see Figure 18). Secure the keyswitch with the large switch nut. Use bolt cutters to trim the two screws closest to the case edge so they will clear the circuit board (see Figure 19).
4. Plug the two keyswitch snap-on wire leads (supplied with the switch) onto the keyswitch **COM** and **N.O.** pins (see Figure 19).
5. Replace the RE-1 circuit board. Secure the board with the four screws. Reconnect the antenna terminal block and wiring harness connector.
6. Connect one keyswitch wire to the RE-1 **OPEN #1** terminal. Connect the other keyswitch wire to the RE-1 **COMMON** terminal.

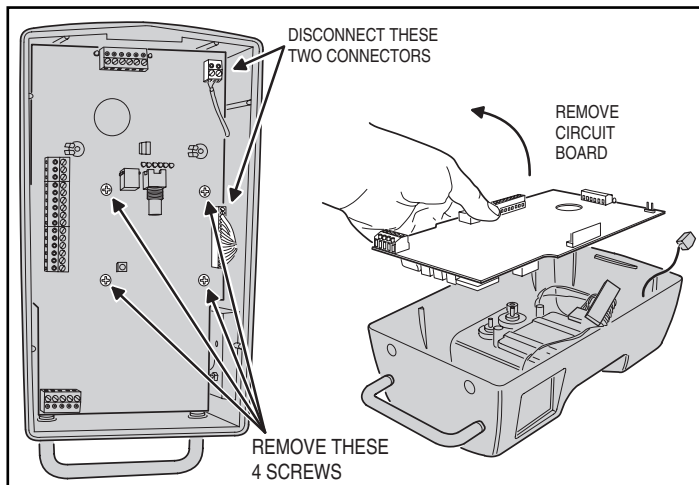

Figure 16. Removing the RE-1 Circuit Board

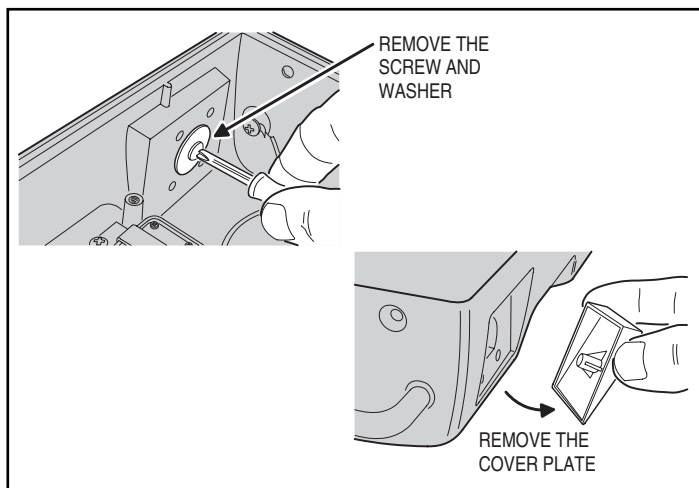

Figure 17. Removing the Keyswitch Hole Access Plate

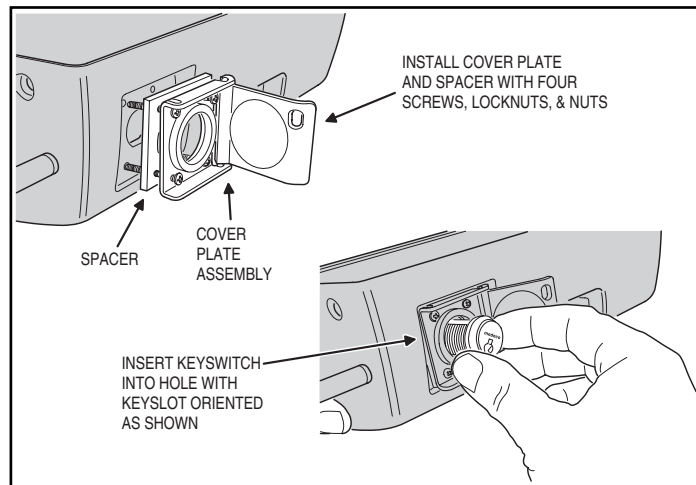

Figure 18. Installing the Keyswitch

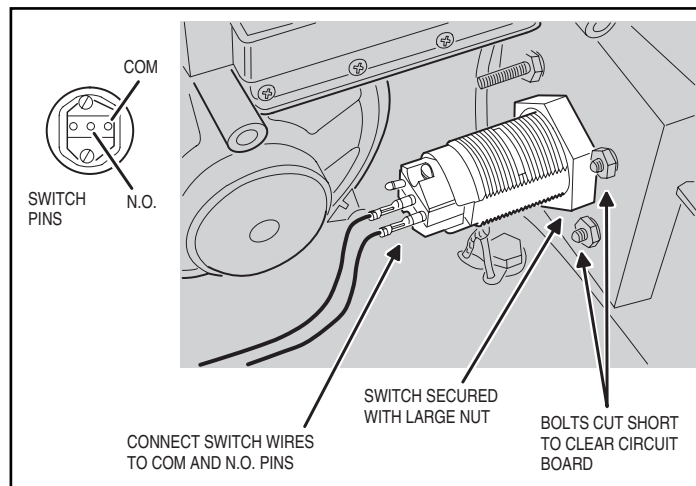

Figure 19. Keyswitch Wire Connections

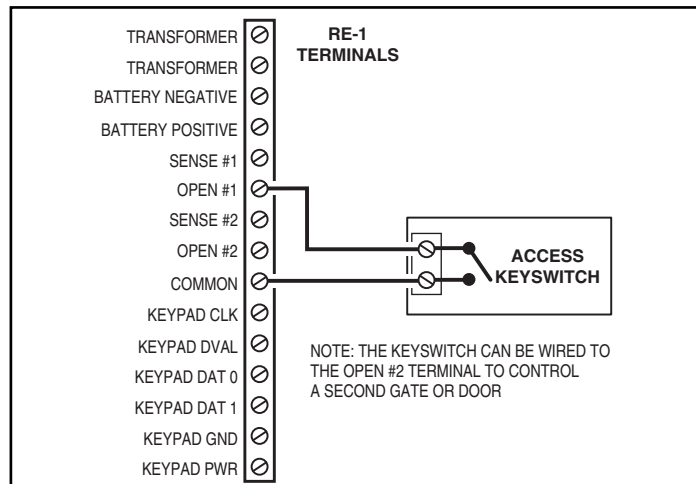

Figure 20. Keyswitch Wiring

OPTIONAL CCTV CAMERA

Linear's Model RE-BWC (P/N ACP00886) CCTV camera can be installed inside the RE-1 Entry System. The camera provides a video signal for viewing the area in front of the entry system.

The camera is continuously powered by the RE-1. The camera's infrared light emitters illuminate the area directly on front of the entry system for nighttime or low light operation.

The RE-1 **CAMERA** jack is used to connect the camera to the main circuit board with the double-ended modular cable supplied with the camera. This cable routes power to, and video from the camera.

The RE-1 **VIDEO** jack is for connection to a video cable with a Type "BNC" connector. Up to 300 feet of 75-ohm RG-59 video cable can be used. Longer cable runs may require the use of a video amplifier.

Camera Installation

1. Disconnect the wiring harness connector and remove the antenna terminal block. Remove the four circuit board retaining screws and the RE-1 circuit board (see Figure 21).
2. Mount the camera assembly into the RE-1 case. Secure the camera with the two screws provided (see Figure 22).
3. Connect the wiring harness 2-pin lighting power wiring connector onto the camera's infrared lighting power connector (see Figure 23).
4. Replace the RE-1 circuit board. Secure the board with the four screws. Reconnect the antenna terminal block and wiring harness connector.
5. Plug the double-ended modular cable into camera's jack and the RE-1 **CAMERA** jack (see Figure 24).
6. Connect the video cable to the RE-1 **VIDEO** connector (see Figure 25).

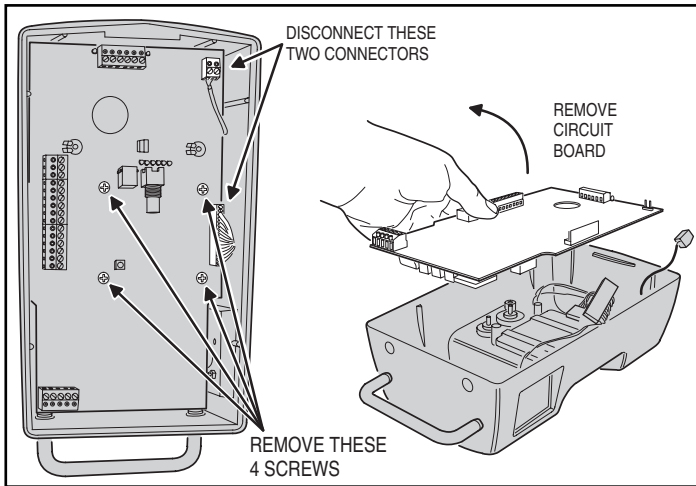

Figure 21. Removing the RE-1 Circuit Board

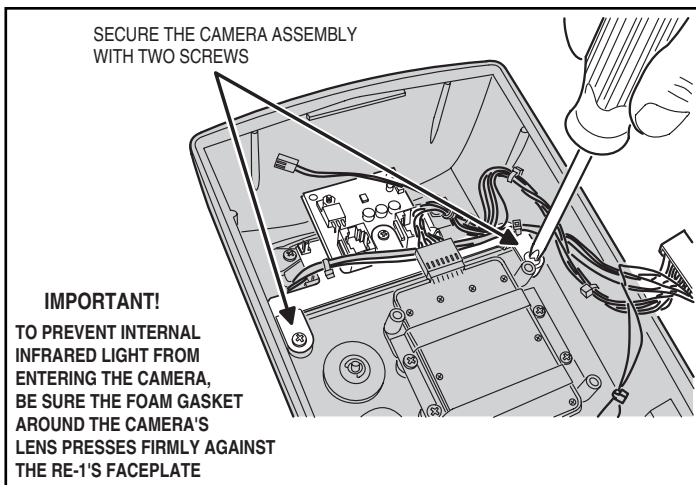

Figure 22. Mounting the Camera in the RE-1

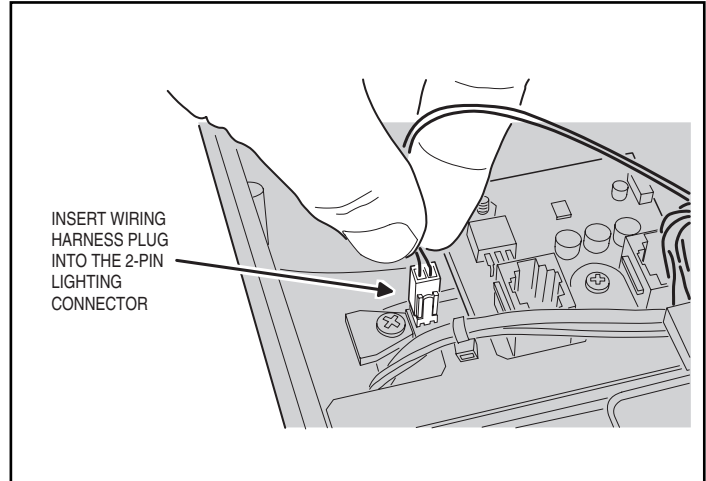

Figure 23. Connecting the Camera's Lighting Power

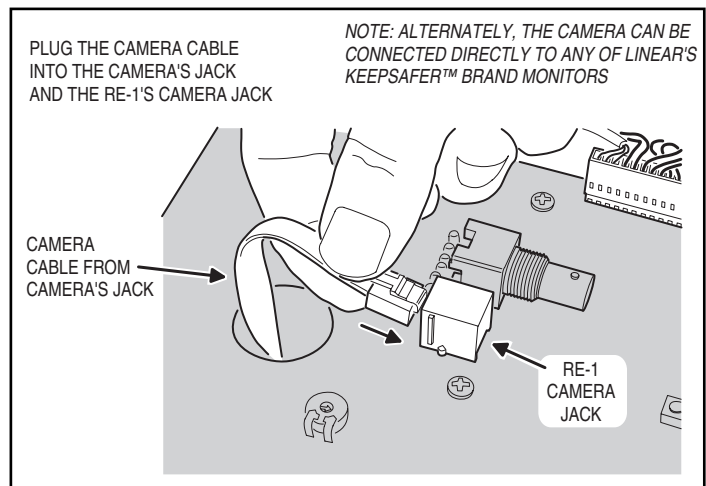

Figure 24. Connecting the Camera Cable

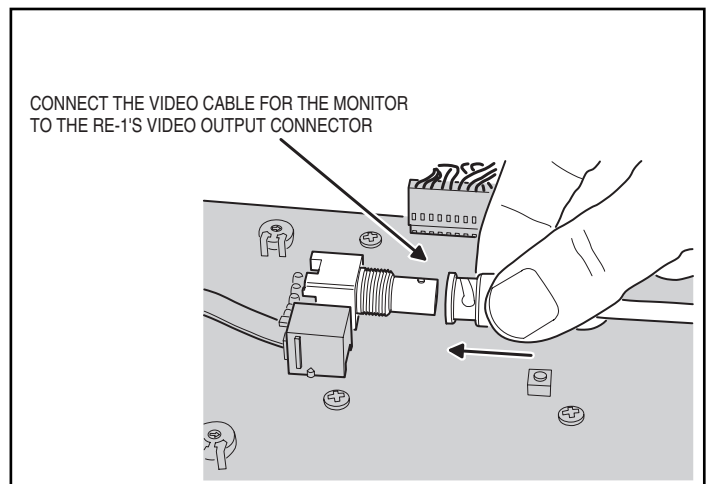

Figure 25. Connecting the Video Cable

PROGRAMMING REFERENCE

PROGRAMMING CONTROL

USAGE	KEYSTROKES
ENTER PROGRAMMING	###MASTER CODE#
ESCAPE/CANCEL	*
EXIT PROGRAMMING	99#

PROGRAM POSITION NUMBERS (PPN)

ENTRY CODE LENGTH	PPN 1..PAGE 14
ENTRY CODES	PPN 2..PAGE 14
DELETE SINGLE ENTRY CODE	PPN 3..PAGE 14
ACCESS GROUP FOR TRANSMITTERS	PPN 4..PAGE 14
ACTIVATE/SUSPEND A SINGLE TRANSMITTER	PPN 5..PAGE 14
ASSIGN A TEMPORARY ACCESS CODE	PPN 6..PAGE 14
ASSIGN TRANSMITTER BUTTONS TO RELAYS	PPN 8..PAGE 14
SET TIME ZONES	PPN 10..PAGE 13
SET HOLIDAYS	PPN 12..PAGE 13
SET DATE & TIME	PPN 20..PAGE 13
SET RELAY #1 ON TIME	PPN 21..PAGE 16
SET RELAY #2 ON TIME	PPN 22..PAGE 16
SET KEYPAD RELAY AND TIME ZONE	PPN 23..PAGE 16
RELAY #2 ALARM FUNCTION	PPN 24..PAGE 16
MGT GATE EDGE TRANSMITTER SETUP	PPN 26..PAGE 16
RELAY #2 FUNCTION	PPN 27..PAGE 16
SET AM-KP REMOTE KEYPAD ADDRESS	PPN 28..PAGE 16
SET INPUT TO SENSE OR INHIBIT	PPN 29..PAGE 16
SET KEYPAD LOCKOUT COUNT	PPN 30..PAGE 16
SET ANTI-PASSBACK TIME	PPN 31..PAGE 16
SET MAXIMUM VISITOR CALL RINGS	PPN 32..PAGE 15
ENABLE/DISABLE AUTOMATIC MODEM ANSWER	PPN 33..PAGE 15
SET DIALING METHOD	PPN 34..PAGE 15
ENABLE/DISABLE BEEPS WHEN KEY IS PRESSED	PPN 40..PAGE 17
ENABLE/DISABLE BEEP DURING RELAY #1	PPN 41..PAGE 17
ENABLE/DISABLE BEEP DURING RELAY #2	PPN 42..PAGE 17
SET RELAY BEEPER DURATION	PPN 43..PAGE 17
ENABLE/DISABLE VOICE SYNTHESIZER	PPN 44..PAGE 17
SET VISITOR TALK TIME LIMIT	PPN 45..PAGE 15
ENABLE/DISABLE DAYLIGHT SAVINGS TIME AUTOMATIC ADJUSTMENT	PPN 46..PAGE 17
ENABLE/DISABLE CALL WAITING	PPN 50..PAGE 15
SET "DO NOT DISTURB" MESSAGE TIME	PPN 51..PAGE 15
ENABLE INTERCOM MODE	PPN 52..PAGE 15
SET AUTOMATIC GATE/DOOR OPEN TIME	PPN 53..PAGE 17
SET CALL FORWARDING TIME AND NUMBER	PPN 54..PAGE 15
SET ALTERNATE RESIDENT TELEPHONE NUMBERS	PPN 55..PAGE 15
SET RESIDENCE RESPONSE TELEPHONE KEYS	PPN 71..PAGE 15
SET RESIDENCE INITIATED COMMAND CODES	PPN 72..PAGE 16
DELETE ALL BLOCK-CODED TRANSMITTERS	PPN 95..PAGE 14
DELETE ALL ENTRY CODES	PPN 97..PAGE 14
CHANGE MASTER CODE	PPN 98..PAGE 13
RESET TO DEFAULTS	PPN 200..PAGE 16

FACTORY DEFAULTS

PPN 1	ENTRY CODE LENGTH	4 DIGITS
PPN 8	TRANSMITTER LEFT (OR TOP LEFT) BUTTON ACTIVATES	RELAY #1
	TRANSMITTER RIGHT (OR TOP RIGHT) BUTTON ACTIVATES	RELAY #2
	TRANSMITTER TOP BUTTON ACTIVATES	RELAYS #1 AND #2
	TRANSMITTER LOWER LEFT BUTTON ACTIVATES	NONE
	TRANSMITTER LOWER RIGHT BUTTON ACTIVATES	NONE
PPN 10	ENTRY TIME ZONES	DISABLED
PPN 12	HOLIDAYS SET	NONE SET
PPN 20	DATE & TIME SET	NOT SET
PPN 21	RELAY #1 ON TIME	2 SECONDS
PPN 22	RELAY #2 ON TIME	2 SECONDS
PPN 23	MAIN KEYPAD ACTIVATES	RELAY #1
PPN 23	REMOTE KEYPAD ACTIVATES	DISABLED
PPN 24	RELAY #2 ALARM FUNCTION	DISABLED
PPN 26	MGT GATE EDGE TRANSMITTER	DISABLED
PPN 27	RELAY #2 FUNCTION	2ND GATE OR DOOR
PPN 28	AM-KP REMOTE KEYPAD ADDRESS	3
PPN 29	SENSE OR INHIBIT INPUTS	
	RELAY #1	SENSE
	RELAY #2	SENSE
PPN 30	KEYPAD LOCKOUT COUNT	5 TRIES BEFORE LOCKOUT
PPN 31	ANTI-PASSBACK TIME	ANTI-PASSBACK DISABLED
PPN 32	MAXIMUM VISITOR CALL RINGS	5 RINGS
PPN 33	AUTOMATIC MODEM ANSWER	ENABLED
PPN 34	DIALING METHOD (TONE OR PULSE)	TONE
PPN 40	BEEPER SOUNDS WHEN KEY PRESSED	YES
PPN 41	BEEPER SOUNDS DURING RELAY #1	NO
PPN 42	BEEPER SOUNDS DURING RELAY #2	NO
PPN 43	RELAY BEEPER DURATION	1 SECOND
PPN 44	VOICE SYNTHESIZER	ENABLED
PPN 45	VISITOR TALK TIME LIMIT	60 SECONDS
PPN 46	DAYLIGHT SAVINGS TIME AUTOMATIC ADJUSTMENT	ENABLED
PPN 50	CALL WAITING	ENABLED
PPN 51	"DO NOT DISTURB" MESSAGE	DISABLED
PPN 53	AUTOMATIC GATE/DOOR OPEN TIME SET	NOT SET
PPN 55	CALL FORWARDING TIME SET	NOT SET
PPN 56	CALL FORWARDING NUMBER	NONE SET
PPN 57	CALL FORWARDING EXTENSION DELAY	NONE SET
PPN 58	CALL FORWARDING	DISABLED
PPN 71	RESIDENCE RESPONSE TELEPHONE KEYS	
	1 - ACTIVATE RELAY #1	
	2 - ACTIVATE RELAY #2	
	6 - SWITCHES TO/FROM CALL WAITING	
	9 - DISCONNECT VISITOR	
PPN 72	RESIDENCE PROGRAMMING PREFIX	###
PPN 72	RESIDENCE INITIATED COMMAND PREFIX	#
PPN 98	MASTER PROGRAMMING CODE	123456

PROGRAMMING ACCESS

The RE-1 can be programmed locally or remotely. The system's built-in programming software can be accessed on-site or off-site using a computer with any Internet browser.

Without a computer, the RE-1 can be programmed from its main keypad, from any local TouchTone® telephone connected to the same line, or from any remote TouchTone® telephone by calling the unit. To guide you through the programming, the RE-1's voice synthesizer will announce programming prompts over the telephone.

Programming with a Computer

Navigating through the RE-1's programming "pages" is similar to browsing through your favorite web site's pages. Anyone familiar with the Internet will find programming the RE-1 with a computer very easy. The RE-1's memory contains the "pages" that the computer will view. When selections and changes are made on the computer, the RE-1's memory is programmed to your custom settings.

System Requirements

◆ **NOTE:** These requirements are for a PC running the Windows™ operating system. For other types of computers and operating systems call Linear Technical Services for assistance.

1. A dial-up modem must be installed.
2. Dial-up networking must be installed.
3. An internet browser must be installed.

Creating a Local Computer Dial-up Connection

1. From "My Computer" select "Dial-up Networking" and select "Make New Connection".
2. Name the connection "Local RE-1" and verify that the installed modem is listed as the device then select "Next".
3. For the telephone number enter "####", select "Next", then select "Finish".

◆ **NOTE:** The "####" prefix to access programming is the default value for the RE-1. It can be changed in the RE-1 using PPN #72. Be sure the prefix entered as the telephone number matches what has been set in the RE-1 if it has been changed from the default.

4. Right-click on "Local RE-1" and select "Properties".
5. From the "General" tab, in the "Connect Using" area, select "Configure...".
6. From the "General" tab, in the "Speaker volume area", set the volume to "High".
7. Select the "Connection" tab.
8. Select "Advanced...".
9. In the "Use error control" area, de-select "Compress data" and select "OK".
10. Select "OK" again.
11. Select the "Server Types" or "Networking" tab.
12. In the "Advanced Options" area, de-select "Enable software compression".
13. In the "Allowed network protocols" area, de-select "NetBEUI" and de-select "IPX/SPX Compatible". Only "TCP/IP" should be selected.
14. Select "TCP/IP Settings...".
15. Select "Specify an IP address".
16. Enter "192.168.20.11" as the "IP address".
17. De-select "Use IP header compression" and de-select "Use default gateway on remote network" then select "OK".
18. Select "OK" again to complete the properties settings.

Connecting Locally

1. Start your browser software. If your browser is set to automatically dial your normal Internet provider when the browser is opened, cancel the dialing when it starts.
2. Start "Dial-up networking".
3. Double-click on "Local RE-1". (The Local RE-1 icon can be dragged to the desktop for easy future access).

4. Enter the RE-1's programming master password (123456, unless changed) into the "Password" area. Select "Save Password" if you want the computer to retain the password.
5. Select "Connect" and wait for the modem to connect to the RE-1.
6. Switch to the browser software and enter into the address line: "http://192.168.20.10/re1.html" (save this address as a "favorite" or "bookmark" so you won't have to enter it each time you connect).
7. Follow the screen links to select the RE-1 items to program.
8. When finished programming, double-click on the dial-up networking icon in the status area of the task bar and select "Disconnect" to terminate the connection.

◆ **NOTE:** Be sure to disconnect when programming is completed.

Creating Remote Computer Dial-up Connection

1. From "My Computer" select "Dial-up Networking" and select "Make New Connection".
2. Name the connection "Remote RE-1" and verify that the installed modem is listed as the device the select "Next".
3. For the telephone number enter the telephone number of the line that the RE-1 is installed on, select "Next", then select "Finish".
4. Right-click on "Remote RE-1" and select "Properties".
5. From the "General" tab, in the "Connect Using" area, select "Configure...".
6. From the "General" tab, in the "Speaker volume area", set the volume to "High".
7. Select the "Connection" tab.
8. Select "Advanced...".
9. In the "Use error control" area, de-select "Compress data" and select "OK".
10. Select "OK" again.
11. Select the "Server Types" or "Networking" tab.
12. In the "Advanced Options" area, de-select "Enable software compression".
13. In the "Allowed network protocols" area, de-select "NetBEUI" and de-select "IPX/SPX Compatible". Only "TCP/IP" should be selected.
14. Select "TCP/IP Settings...".
15. Select "Specify an IP address".
16. Enter "192.168.20.11" as the "IP address".
17. De-select "Use IP header compression" and de-select "Use default gateway on remote network" then select "OK".
18. Select "OK" again to complete the properties settings.

Connecting Remotely

1. Start your browser software. If your browser is set to automatically dial your normal Internet provider when the browser is opened, cancel the dialing when it starts.
2. From "My Computer" select "Dial-up networking".
3. Double-click on "Remote RE-1". (The Remote RE-1 icon can be dragged to the desktop for easy future access).
4. Enter the RE-1's programming master password (123456, unless changed) into the "Password" area. Select "Save Password" if you want the computer to retain the password.
5. Select "Connect" and wait for the modem to dial the RE-1.
6. Select "Cancel" after two rings.
7. Wait about 10 seconds, but not longer than 30 seconds, then repeat Steps 3-5. The RE-1 should answer.
8. Wait for the connection to establish.
9. Switch to the browser software and enter into the address line: "http://192.168.20.10/re1.html" (save this address as a "favorite" or "bookmark" so you won't have to enter it each time you connect).
10. Follow the screen links to select the RE-1 items to program.
11. When finished programming, double-click on the dial-up networking icon in the status area of the task bar and select "Disconnect" to terminate the connection.

◆ **NOTE:** Be sure to disconnect when programming is completed.

Programming with a Local Telephone or the Unit's Keypad

Start with Step 1 below for local programming with the unit's keypad or a local telephone.

1. Enter "###" (unless the programming prefix has been changed) then the Master Programming Code (123456, unless it has been changed), then "#".
 2. Use the telephone keys or keypad to make any programming changes. Refer to the next section for details of the keystrokes for each programming PPN. The voice synthesizer will sound programming prompts.
 3. To disconnect after programming, enter "99#".
- ◆ **NOTE:** The RE-1 will automatically exit programming mode after five minutes of no programming activity.

Remote Programming with a Telephone

For remote programming, the RE-1 can be called from any TouchTone® telephone. Once the connection is made, the programming keystrokes are identical to what would be entered at the unit's keypad or from a local telephone. Refer to the next section for details of the keystrokes for each programming PPN.

Remote Telephone Connection

1. Dial the telephone number of the line that the RE-1 is connected to.
2. Let the telephone ring once and hang up.
3. After 10 seconds, but before 30 seconds, call back to the same telephone number.
4. The RE-1 will answer and sound a tone for 2 seconds.
5. The RE-1 will wait for approximately six seconds for the caller to enter the Master Programming Code.
6. Enter password (123456, unless it has been changed), then "#".
7. Use the telephone keypad to make any programming changes. Refer to the next section for details of the keystrokes for each programming PPN. The voice synthesizer will sound programming prompts.
8. To disconnect after programming, enter "99#".

◆ **NOTE:** Programming worksheets are supplied at the rear of this manual for writing down other programming selections.

MASTER CODE					

BASIC SYSTEM PROGRAMMING

Entering Programming Mode

The 6-digit Master Programming Code (default = 123456) is used to enter Programming Mode from a local or remote telephone or the keypad.

Press: Master Code

Master Code = the current 6-digit Master Programming Code

Exiting Programming Mode

Press:

◆ **NOTE:** The RE-1 will automatically exit Programming Mode after five minutes of programming inactivity.

Re-entering a Command After a Mistake

If an incorrect entry, or an incorrect key is pressed during programming, to clear the keypad:

Press:

Changing the Master Code

Use this PPN to change the six-digit Master Programming Code. Be sure to write down the new code.

Press: New Master Code New Master Code

Setting the Clock And Calendar

The time and date set in the clock and calendar control the system time zones, holiday schedules, and time stamping of the event log. The GTZ setting controls when the downlight is on. The RE-1 has an on-board lithium battery to maintain the date and time if power is removed from the unit.

Press: Day of Week Month Day

Year Hour Minute AM/PM GTZ

Day of Week: 1 = Sun; 2 = Mon; 3 = Tue; 4 = Wed; 5 = Thu; 6 = Fri; 7 = Sat

Month = 1-12; Day = 1-31; Year = 2000-2127;

Hour = 1-12 (in Standard Time)

Minute = 0-59; AM/PM: 0 = AM; 1 = PM

GTZ (Geographic Time Zone): 0 = None (disables nighttime keypad lighting);

1 = Eastern; 2 = Central; 3 = Mountain; 4 = Pacific; 5 = Alaska; 6 = Hawaii

Setting the Time Zones

Seven time zones are available for restricting access, automatic gate entry, call forwarding schedule, assigning an access groups for transmitters, assigning a temporary entry code, and setting the "Do Not Disturb" schedule. A time zone constrained event will be allowed or occur between the start and end times on the active days selected.

Press: Time Zone Number Active Days

Start Hour Start Minute AM/PM End Hour

End Minute AM/PM

Time Zone Number = 1-7

Active Days (Enter up to 8 digits):

1 = Sun; 2 = Mon; 3 = Tue; 4 = Wed; 5 = Thu; 6 = Fri; 7 = Sat; 8 = Holidays

Start Hour = 1-12 Start Minute = 0-59 AM/PM: 0 = AM; 1 = PM

End Hour = 1-12 End Minute = 0-59 AM/PM: 0 = AM; 1 = PM

Setting the Holiday Days

Up to ten holidays can be programmed. Holidays are used to restrict access on holiday days. If an entry method (code or transmitter) is assigned to a time zone, holidays must be set as an active day to allow access on holidays.

Press: Holiday Number Month Day

Holiday Number = 1-10

Month = 1-12

Day = 1-31

ENTRY CODE PROGRAMMING

Setting the Entry Code Length

Default: 4 digits

Sets the number of digits for all the entry codes programmed.

Press: **1** **⏏** Length **⏏**

Length = 2 - 6 for entry code length

◆ **NOTE:** If the Entry Code Length is going to be changed from the factory default of four digits, make this change first, before programming any entry codes.

Adding a New Entry Code

Use this PPN to add up to 100 entry codes.

Press: **2** **⏏** Code **⏏** Code **⏏** Relay **⏏**
⏏ Time Zone **⏏**

Code = The new entry code: 1-999999, depending on code length

Relay = Relay output entry code will activate:

1 = Relay #1 2 = Relay #2 3 = Both Relays

4 = Latch Relay #1 (no access restrictions, **latches relay**, unlatch relay by re-entering code) Also see PPN #23

Time Zone = 0 = no time zone; 1-7 to restrict access per time zone 1-7

If the new entry code chosen is already being used for another entry code, the system will reject the code. A new unique entry code needs to be entered.

◆ **NOTE:** Leading zeros (zeros before the code number, i.e. 0001) do not need to be entered when programming a new entry code. The RE-1 will internally add any zeros to fill all digits determined by the entry code length setting. Leading zeros **will** have to be entered by the user when entering their code to gain access.

Adding a Temporary Entry Code

Temporary entry codes with a starting and ending date can be created to permit limited access. Temporary entry codes will expire and no longer be able to grant access outside the programmed dates and a programmed number of uses. The total number of temporary and regular entry codes cannot exceed 100.

Press: **6** **⏏** Code **⏏** Code **⏏** Relay **⏏** Time Zone **⏏**
⏏ Number **⏏** Valid From **⏏** Valid Thru **⏏**

Code = The new entry code: 1-999999, depending on code length

Relay = Relay output entry code will activate:

1 = Relay #1 2 = Relay #2 3 = Both Relays

Time Zone = 0 = no time zone; 1-7 to restrict access per time zone 1-7

Number = Number of times (1-255) that the entry code is allowed access

Valid From = First date (MMDDYY) that the entry code is valid

Valid Thru = Last date (MMDDYY) the entry code is valid.

If the new temporary entry code chosen is already being used for another entry code, the system will reject the code. A new unique temporary entry code needs to be entered.

◆ **NOTE:** Leading zeros (zeros before the code number, i.e. 0001) do not need to be entered when programming a new entry code. The RE-1 will internally add any zeros to fill all digits determined by the entry code length setting. Leading zeros **will** have to be entered by the user when entering their code to gain access.

Removing a Single Entry Code

Use this PPN to delete an entry code.

Press: **3** **⏏** Code **⏏** Code **⏏**

Code = The entry code to remove.

Erasing All Entry Codes

★ **WARNING:** This command will remove all entry codes.

Press: **9** **7** **⏏** 000000 **⏏** 000000 **⏏**

TRANSMITTER PROGRAMMING

Adding Transmitters

Up to four groups of transmitters can be assigned common access privileges sharing the same one or two time zones. Up to 100 transmitters total in all groups combined can be used in each RE-1 system.

Press: **4** **⏏** Number **⏏** Facility Code **⏏** First ID **⏏**
⏏ Time Zone 1 **⏏** Time Zone 2 **⏏**

Number = Number of transmitters in the group

Facility Code = Facility code 0-15 marked on block of transmitters;

First ID = 5-digit ID number of first transmitter in group.

Time Zone 1 = 0 = no time zone; 1-7 to restrict access per time zone 1-7

Time Zone 2 = 0 = no time zone; 1-7 to restrict access per time zone 1-7

◆ **NOTE:** If the Time Zone 1 entry is set to "0", the Time Zone 2 entry is ignored.

Suspend or Activate a Transmitter

Each transmitter programmed can be individually suspended from use for access with this programming PPN. The transmitter will remain suspended until it is re-activated using this same programming PPN.

Press: **5** **⏏** Facility **⏏** ID **⏏** Action **⏏**

Facility = Facility code 0-15 of transmitter

ID = 5-digit ID number of transmitter

Action: 0 = Suspend transmitter; 1 = Re-activate transmitter

Erasing All Transmitters

★ **WARNING:** Performing this command will remove all transmitters from the memory.

Press: **9** **5** **⏏** 000000 **⏏** 000000 **⏏**

Assigning Transmitter Buttons to Relays

Defaults:

Left (or Top Left) = Relay #1

Right (or Top Right) = Relay #2

Top Button = Both Relays

Lower Left = None

Lower Right = None

The RE-1 can be programmed to control which relay will activate from which transmitter button. This setting will effect all transmitters (single and multi-channel) used with the RE-1

Press: **8** **⏏** Button **⏏** Relay **⏏**

Button: 1 = Right (or Top Right); 2 = Left (or Top Left)

4 = Top; 5 = Bottom Right; 6 = Bottom Left

Relay: 0 = None; 1 = Relay #1; 2 = Relay #2; 3 = Both Relays

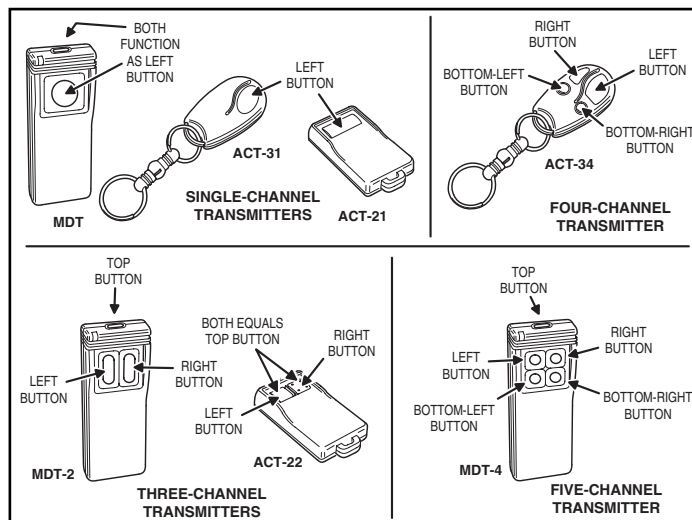

TELEPHONE PROGRAMMING

Maximum Number of Visitor Rings **Default: 5 Rings**

Changes the maximum number of distinctive rings that the RE-1 will generate to the local telephones when the CALL button is pressed.

Press: **3 2** Rings

Rings = 1-15 Rings maximum

Call Forwarding Dialing Method **Default: Tone**

Sets the dialing method used during call forwarding to either tone or pulse style.

Press: **3 4** Method

Method: 1 = Pulse; 2 = Tone

Visitor Talk Time Limit **Default: 60 Seconds**

Sets the time that the visitor is allowed to talk to the resident. Ten seconds before the time expires, the voice synthesizer will announce "ten seconds", and at five seconds it will announce "five seconds", to the visitor. If the voice synthesizer is disabled (PPN #44), a beep will sound each second during the last ten seconds of time allowed.

Press: **4 5** Limit

Limit = 15-255 Seconds allowed

Call Waiting ON/OFF **Default: ON**

Turns the call waiting feature on or off. If call waiting is on (factory default) and the resident is on the telephone at the same time a visitor calls, the RE-1 will generate beeps on the resident's telephone line to signal that a visitor is calling. The resident has the option to switch to the visitor's call.

If the call waiting feature is off and the resident is on the telephone at the same time a visitor calls, the RE-1 will announce "resident busy" to the visitor.

Press: **5 0** Call Waiting

Call Waiting: 1 = ON; 0 = OFF

Privacy Feature Schedule **Default: OFF**

The privacy feature will block visitor's calls and call forwarding during the selected Time Zone or at all times. If the privacy feature is active and a visitor calls, the RE-1 will announce "do not disturb resident". If call forwarding is scheduled (PPN #54) and the privacy feature is active, the RE-1 will announce "do not disturb resident" and visitor's call will not be forwarded.

Press: **5 1** Privacy Time Zone

Privacy: 0 = Privacy feature OFF

1 = Privacy feature ON (scheduled by Time Zone)

2 = Privacy feature ON at all times

Time Zone = 1-7 (Privacy feature active during this Time Zone)

Intercom Mode ON/OFF **Default : OFF**

The RE-1 includes an *Intercom Mode* that allows the unit to be operated independent of the Public Switched Network. In this mode, the RE-1 directly supplies the power for the house telephone(s) connected to it.

To use the RE-1 in intercom mode, connect the telephone line as shown under Telephone Wiring Options on Page 6. Note that the RE-1's Telephone Bypass Module is included in the circuit for additional telephone line surge protection. Be sure the Telephone Bypass Module's switch is in the **NORMAL** position.

NOTE: Because there is no connection to the Public Switched Telephone Network, the call forwarding and alternate resident telephone dialing features will not be available.

This programming step turns the intercom mode on or off. If intercom mode is on, the RE-1 will power the house telephone(s).

If intercom mode is off, the Telephone Company will power the house telephone(s).

Press **5 2** Intercom Mode

Intercom Mode: 1 - ON; 0 - OFF

Call Forwarding Feature **Default: OFF**

The call forwarding feature will allow a visitor to contact the resident at the programmed telephone number instead of through the local telephone line. The feature can be set to be active during a selected Time Zone or at all times. The telephone number programmed can contain an extension number and an optional time delay before dialing the extension.

Press: **5 4** Forwarding Time Zone

Telephone Number Extension Delay

Forwarding: 0 = Call forwarding feature OFF

1 = Call forwarding feature ON at all times

2 = Call forwarding feature ON (scheduled by Time Zone)

3 = Forward the call if there was no resident answer

Time Zone = 1-7 (Call forwarding feature active during this Time Zone)

Telephone Number = Up to 11-digit telephone number

Extension = Up to 4-digit telephone extension number

Delay = 1-25 seconds (delay between telephone number and extension)

Example, call forwarding with only a phone number:

Press: **5 4** **1** Telephone Number

A special feature is implemented for "Ring Down" PBX systems. If no telephone number is programmed and call forwarding is enabled, the unit will connect immediately without dialing.

Alternate Resident Telephone Numbers

For installations where multiple residences exist behind shared controlled access, the RE-1 can dial three alternate telephone numbers. The visitor can call an alternate number by entering "1#", "2#", or "3#" on the main keypad.

Press: **5 5** Location Enable

Telephone Number Extension Delay

Location: 1 = "1#" location 2 = "2#" location 3 = "3#" location

Enable: 0 = Disable; 1 = Unconditionally enable

Telephone Number = Up to 11-digit telephone number

Extension = Up to 4-digit telephone extension number

Delay = 1-25 seconds (delay between telephone number and extension)

Resident Response Keys **Defaults:**

Key A "1" = Activates Relay #1

Key B "2" = Activates Relay #2

Key C "9" = Disconnect Visitor's Call

Key D "6" = Switch To/From Call Waiting

The resident response keys are the telephone keys that the resident uses to grant access and control calls from a visitor. The keys for the four functions can be customized. Enter all four keys each time this programming PPN is used.

Press: **7 1** Keys ABCD

Keys ABCD: Enter 4 digits for the response keys A, B, C, & D

Key A = Activates Relay #1

Key B = Activates Relay #2

Key C = Disconnects the Visitor's Call

Key D = Switches to and from a call holding on call waiting

Resident Programming and Command Prefixes **Defaults:**

Programming = "###"

Command = "##"

The resident *command prefix* is entered on a local telephone prior to entering a command number to control one of the relays or open voice communications with the RE-1. The resident *programming prefix* is entered on a local telephone or the main keypad prior to programming the RE-1.

Press: **7 2** Programming Command

Programming: 0 = "####" 1 = "***", 2 = "**#", 3 = "##"

Command: 0 = "##" 1 = "**", 2 = "*#", 3 = "*"

ADVANCED SYSTEM PROGRAMMING

Reset System Defaults

The system can be reset back to the factory defaults with this programming PPN. EXECUTING THIS PPN WILL NOT ERASE ANY ENTRY CODES OR TRANSMITTERS THAT HAVE BEEN PROGRAMMED.

Press: **2 0 0** 

Relay #1 On Time

Default 2: Seconds

Changes the length of time Relay #1 activates when triggered.

Press: **2 1**  **Time** 

Seconds = Output time in seconds 0-60

Relay #2 On-time

Default: 2 Seconds

Changes the length of time Relay #2 activates when triggered.

Press: **2 2**  **Time** 

Seconds = Output time in seconds 0-60

Main & Remote Keypad Relay and Time Zone

Default: Main Keypad = Relay #1, No Time Zone

Remote Keypad = Disabled

Sets the relay and time zone that the main and remote keypad will use.

Press: **2 3**  **Keypad**  **Relay**  **Time Zone** 

Keypad: 1 = Main Keypad

2 = Remote Keypad

(Also see PPN #28)

Relay: 1 = Relay #1

2 = Relay #2

3 = Set by entry code

Time Zone: 0 = no time zone

1-7 to restrict access per time zone 1-7

◆ **NOTE:** To have an entry code select which relay activates, the relay option should be set to "3".

Relay #2 Alternate Options

Default: Access Relay

Relay #2 can be used for functions other than triggering a gate operator or door strike. Relay #2 can be programmed to shunt alarm contacts during Relay #1 activation or perform up to five Alarm Functions. Two PPN numbers are used to program the Relay #2 options.

Press: **2 7**  **Role** 

Role: 0 = Access Relay

1 = Alarm Shunt (Follows Relay #1 activation, used to shunt external alarm contacts with Relay #2's contacts)

2 = Obstacle Detector

3 = Activate during one or more of the five Alarm Functions programmed below

◆ **NOTE:** More than one alarm function can be enabled at a time. Up to five digits can be entered for "Activate".

Press: **2 4**  **Activate** 

Activate: 0 = No alarm function (default)

1 = On forced entry (activates when SENSE #1 input opens without Relay #1 activation)

2 = On door/gate ajar (activates when SENSE #1 input stays open for longer than one minute after Relay #1 activation)

3 = On main keypad lockout (activates when the main keypad is in "lockout" from too many incorrect code attempts)

4 = On remote keypad lockout (activates when the remote keypad is in "lockout" from too many incorrect code attempts)

5 = On driveway sensor (activates when SENSE #2 input closes)

Model MGT Gate Edge Transmitter Setup

Linear's Model MGT Gate Edge Transmitter can be used with the RE-1 for obstacle detection. When the gate edge sensor triggers the MGT transmitter, the RE-1 can be programmed to activate Relay #2 which would in turn, activate the obstacle input of the gate operator.

Press: **2 6**  **Obstacle**  **Facility**  **ID** 

Obstacle: 0 = No MGT obstacle transmitter (default)

1 = MGT obstacle transmitter used

Facility: Facility code 0-15 of MGT transmitter

ID = 5-digit ID number of transmitter

◆ **NOTE:** The Facility and ID entries are not required if Obstacle is set to "0".

Remote Keypad Address

Default: 3

If a Linear Model AM-KP is used as a remote keypad the ADDRESS switch in the remote keypad needs to match the "address" setting in the RE-1. For most installations, simply set the remote keypad's ADDRESS switch to "3" to match the RE-1 default setting. If required, use the following programming PPN to change the address number.

Press: **2 8**  **Address** 

Address: 0 = Remote keypad disabled

1-6 = Keypad address 1-6

◆ **NOTE:** After changing the keypad address, restart the system using the RESTART button.

Sense Input Alternate Function

Defaults:

SENSE #1 = SENSE

SENSE #2 = SENSE

Each of the two SENSE inputs can be independently programmed to act as INHIBIT inputs. As an INHIBIT input, as long as the input is grounded, access can not be granted for that input's relay (1 or 2). A typical application would be connection of an external timer or service switch to temporarily prevent visitors from activating the access device.

Press: **2 9**  **Input**  **Type** 

Input: 1 = SENSE #1

2 = SENSE #2

Type: 0 = Input will perform as SENSE

1 = Input will perform as INHIBIT

Keypad Lockout Count

Default: 5 Tries

The Keypad Lockout Count sets the number of incorrect code entry attempts required to place the keypad in "lockout" for a three minute period. During "lockout" the keypad will not accept any code entries. The Keypad Lockout Count effects both the main and remote keypads.

Press: **3 0**  **Count** 

Count = 2-7 Incorrect entries

Anti-passback Time

Default: Disabled

The Anti-passback feature prevents the same entry code or transmitter from being used to gain access more than once during the set time.

Press: **3 1**  **Time** 

Time: 0 = No anti-passback

1-4 = Anti-passback time (in minutes)

Modem Ring Detect

Default: Enabled

The RE-1's built-in modem monitors the telephone line for telephone rings. When the Modem Ring Detect is enabled, the modem will answer the telephone if two consecutive telephone calls occur within 30 seconds. The Modem Ring Detect can be disabled, this will also disable any computer based programming of the RE-1.

Press: **3 3**  **Detect** 

Detect: 0 = Disable

1 = Enable

Keypad Beeps **Default: On**

The default setting causes the main keypad to beep when each key is pressed. The beeps can be disabled.

Press: **4** **0** **⏏** Keypad Beeps **⏏**

Keypad Beeps: 0 = No beeps
1 = Beeps

Relay #1 Tone **Default: Off**

The default setting does not cause the annunciator to sound when Relay #1 is activated. The Relay #1 activation tone can be enabled.

Press: **4** **1** **⏏** Relay #1 Tone **⏏**

Relay #1 Tone: 0 = No Sound
1 = Sound

Relay #2 Tone **Default: Off**

The default setting does not cause the annunciator to sound when Relay #2 is activated. The Relay #2 activation tone can be enabled.

Press: **4** **2** **⏏** Relay #2 Tone **⏏**

Relay #2 Tone: 0 = No Sound
1 = Sound

Relay Sound Duration **Default: 1 Second**

The default setting causes the annunciator to sound for 1 second when Relay #1 or Relay #2 is activated (if the sounds are enabled). The length of the activation annunciation can be changed.

Press: **4** **3** **⏏** Sound Length **⏏**

Sound Length = Tone length in Seconds 1-15

Voice Synthesizer ON-OFF **Default: ON**

When the voice synthesizer is on the RE-1 will sound voice prompts during operation and programming. If the voice synthesizer is off, the system will sound beeps to indicate conditions. The HELP button will announce "Enter code or press call button to contact resident" regardless of this setting.

The beeps produced when the voice synthesizer is off are:

- 1 Short beep — Keypad key pressed
- 2 Short beeps — Programming entry was valid
- 1 Long beep — Programming entry was invalid

Press: **4** **4** **⏏** Voice **⏏**

Voice: 0 = Voice synthesizer OFF
1 = Voice synthesizer ON

Automatic Daylight Savings Time Clock Adjustment **Default: ON**

The RE-1's internal clock used for controlling system functions and time stamping of the event log automatically adjusts for daylight savings time. For areas where daylight savings time is not observed, this feature may be disabled.

Press: **4** **6** **⏏** Daylight Savings **⏏**

Daylight Savings: 0 = Daylight Savings Adjust OFF
1 = Daylight Savings Adjust ON

Automatic Door/Gate Open Time **Default: Disabled**

Each control relay can be programmed for automatic activation. One or two Time Zones can be assigned to a relay. The relay will activate and remain latched during the active period of the Time Zone.

Press: **5** **3** **⏏** Relay **⏏** 1st Time Zone **⏏** 2nd Time Zone **⏏**

Relay: 1 = Relay #1
2 = Relay #2

1st Time Zone = Time Zone 1-7

2nd Time Zone = Time Zone 1-7 (enter "0" if the 2nd time zone is not used)

SYSTEM ADJUSTMENTS

The RE-1 Entry System audio levels can be adjusted to suit the installation requirements. If required, make these adjustments after programming, but before closing and securing the RE-1 case.

Speakerphone Volume

The **SPEAKERPHONE VOLUME** adjustment controls the audio level that the RE-1 speaker produces during communications between the visitor and the resident.

♦ **NOTE:** Adjusting the speaker volume too high will cause the speech to cut-out as the system switches from talk to listen.

1. Have someone waiting to receive the call. Push the **CALL** button to call the residence.
2. Have the resident talk at a normal volume level while adjusting the **SPEAKERPHONE VOLUME** control. Adjusting the control clockwise increases the volume, counterclockwise decreases the volume.

Digital Speech Volume

The **DIGITAL SPEECH VOLUME** adjustment controls the audio level of the voice synthesizer. This adjustment effects the audio level of the voice synthesizer from the speaker and through the telephone.

1. Push the **HELP** button to cause the voice synthesizer to sound the help message.
2. Adjust the **DIGITAL SPEECH VOLUME** to suit the installation. Adjusting the control clockwise increases the volume, counterclockwise decreases the volume.

RE-1 OPERATION

Requesting Access with an Entry Code

- Visitors have up to 40 seconds to key in their entry code.
- Up to eight seconds are allowed between each keystroke.
- All digits of the entry code must be entered. Example: If the code is 0042, the user must enter "0 0 4 2".
- If the wrong key is pressed, pressing the ***** key will reset the keypad. The correct code can then be entered.
- After a correct code is entered, and if the conditions for granting access are fulfilled, the programmed relay will activate for the programmed time.
- If the number of incorrect codes entered exceeds the keypad lockout count, the keypad will be locked and not accept any entries for one minute.
- If the Anti-passback feature is enabled, the entry code will be unusable until the anti-passback time expires.

Requesting Access with a Wireless Transmitter

- Activate a wireless transmitter within radio range (up to 300 feet) of the RE-1.
- After a valid transmitter is decoded, and if the conditions for granting access are fulfilled, relay will activate for the programmed time.
- If the Anti-passback feature is enabled, the transmitter will be unusable until the anti-passback time expires.

Requesting Access with a Visitor Call

- The visitor presses the CALL button.
 - The RE-1 disconnects the local telephones from the incoming telephone line and generates distinctive rings to the local telephones.
 - The resident answers the call and converses with the visitor to determine if access will be granted.
 - If the resident is using the telephone at the same time a visitor calls, and the Call Waiting feature is enabled, the RE-1 will sound beeps on the telephone line to notify that a visitor is calling. The resident can place the outside caller on hold and switch to (and from) the visitor by pressing **6** on the telephone.
 - The resident can use the telephone's keypad to grant access activating Relay #1 by pressing **1**, or activating Relay #2 by pressing **2**.
 - The resident can disconnect the visitor without granting access by pressing **9** or by hanging up.
 - If the Call Forwarding feature is enabled, the system will forward the visitor's call to an outside telephone number during the programmed time for call forwarding. The resident can control access from the forwarded telephone number.
 - The system can be programmed to produce a "Do Not Disturb" message for the visitor during times when privacy is desired. No call will be generated to the residence and access will be denied.
 - Pressing the ***** key will cancel the call.
- ◆ **NOTE:** The telephone control keys are programmable and can be changed (see PPN #71).

Requesting Access with a Visitor Call to an Alternate Number

- The system can be programmed to provide up to three alternate telephone numbers to dial for installations where multiple residences are secured by shared controlled access.
- The visitor can call the alternate telephone numbers by pressing: **1** **#**, **2** **#**, or **3** **#**. The three numbers are defined by programming.

Residence Telephone Commands

- The system can be controlled by the resident *without* a call from a visitor by using any telephone connected to the local line.
 - To activate and latch Relay #1 press **# # 8 1 #**
 - To activate and latch Relay #2 press **# # 8 2 #**
 - To release Relay #1 press **# # 8 3 #**
 - To release Relay #2 press **# # 8 4 #**
 - To begin voice communications with the RE-1 press **# # 8 5 #**
- ◆ **NOTE:** The "##" command prefix is programmable and can be changed (see PPN #72).

Obstacle Transmitter Supervision

- If the Model MGT obstacle transmitter has a supervisory condition, a one-second beep will be heard on any telephone connected to the local line when the telephone is off-hook (dialing during this beep is not recommended).
- Servicing the MGT transmitter (replacing the batteries, correcting the tamper condition, etc.) will correct the supervisory condition and stop the one-second beeps.

Remote Telephone Commands

- The system can be operated from a remote phone.
1. Dial the phone number for the RE-1. Wait two rings then hang up.
 2. Wait at least 10, but not longer than 30 seconds and re-dial the phone number for the RE-1.
 3. The RE-1 will answer. Wait for the modem tones to finish then enter your 6 digit password followed by #.
 4. The RE-1 will respond with "Entry OK".
- To latch Relay #1 press **8 1 #**
 - To latch Relay #2 press **8 2 #**
 - To release Relay #1 press **8 3 #**
 - To release Relay #2 press **8 4 #**
 - The RE-1 will respond with "Entry OK".
 - To disconnect press **9 9 #**

RESIDENT PROGRAMMING QUICK REFERENCE

Some of the programming PPN's may be commonly used by the resident. Following are quick references to the keystrokes required.

◆ **NOTE:** The "###" is the default command prefix. The following example assumes that the default has not been changed.

To Enter Programming Mode

Press: **[*] [*] [*] Master Code [*]**

Master Code = the current 6-digit Master Programming Code

To Exit Programming Mode & Save Changes

Press: **[9] [9] [*]**

Re-entering a Command After a Mistake

If an incorrect entry, or an incorrect key is pressed during programming, to clear the keypad:

Press: **[*]**

Adding a Entry Code

Press: **[2] [*] Code [*] Code [*] Relay [*] Time Zone [*]**

Code = The new entry code: 1-999999, depending on code length

Relay = Relay output entry code will activate:

1 = Relay #1 2 = Relay #2 3 = Both Relays

4 = Relay #1 as priority user (no access restrictions)

Time Zone = 0 = no time zone; 1-7 to restrict access per time zone 1-7

Adding a Temporary Entry code

Press: **[6] [*] Code [*] Code [*] Relay [*] Time Zone [*] Number [*]**

Valid From [*] Valid Thru [*]

Code = The new entry code: 1-999999, depending on code length

Relay = Relay output entry code will activate:

1 = Relay #1 2 = Relay #2 3 = Both Relays

Time Zone = 0 = no time zone; 1-7 to restrict access per time zone 1-7

Number = Number of times (1-255) that the entry code is allowed access

Valid From = First date (MMDDYY) that the entry code is valid

Valid Thru = Last date (MMDDYY) the entry code is valid.

Removing a Single Entry Code

Press: **[3] [*] Code [*] Code [*]**

Code = The entry code to remove.

Suspend or Activate a Single Transmitter

Press: **[5] [*] Facility [*] ID [*] Action [*]**

Facility = Facility code 1-16 of transmitter (0 = no facility code)

ID = 5-digit ID number of transmitter

Action: 0 = Suspend transmitter; 1 = Re-activate transmitter

Maximum Number of Visitor Rings

Press: **[3] [2] [*] Rings [*]**

Rings = 1-15 Rings maximum

Visitor Talk Time Limit

Press: **[4] [5] [*] Limit [*]**

Limit = 15-255 Seconds allowed

Call Waiting On/Off

Press: **[5] [0] [*] Call Waiting [*]**

Call Waiting: 1 = ON; 2 = OFF

Call Forwarding

Press: **[5] [4] [*] Forwarding [*] Time Zone [*] Telephone Number [*]**

Extension [*] Delay [*]

Forwarding: 0 = Call forwarding feature OFF

1 = Call forwarding feature ON at all times

2 = Call forwarding feature ON (scheduled by Time Zone)

Time Zone = 1-7 (Call forwarding feature active during this Time Zone)

Telephone Number = Up to 11-digit telephone number

Extension = Up to 4-digit telephone extension number

Delay = 1-25 seconds (delay between telephone number and extension)

"Do Not Disturb" Privacy Feature On/Off

Press: **[5] [1] [*] Privacy [*] Time Zone [*]**

Privacy: 0 = Privacy feature OFF

1 = Privacy feature ON (scheduled by Time Zone)

2 = Privacy feature ON at all times

Time Zone = 1-7 (Privacy feature active during this Time Zone)

Automatic Door/Gate Open Time

Press: **[5] [3] [*] Relay [*] 1st Time Zone [*] 2nd Time Zone [*]**

Relay: 1 = Relay #1

2 = Relay #2

1st Time Zone = Time Zone 1-7

2nd Time Zone = Time Zone 1-7 (enter "0" if the 2nd time zone is not used)

Setting Time Zones

Press: **[1] [0] [*] Time Zone Number [*] Active Days [*] Start Hour [*]**

Start Minute [*] AM/PM [*] End Hour [*] End Minute [*] AM/PM [*]

Time Zone Number = 1-7

Active Days (Enter up to 8 digits):

1 = Sun; 2 = Mon; 3 = Tue; 4 = Wed; 5 = Thu; 6 = Fri; 7 = Sat; 8 = Holidays

Start Hour = 1-12 Start Minute = 0-59 AM/PM: 0 = AM; 1 = PM

End Hour = 1-12 End Minute = 0-59 AM/PM: 0 = AM; 1 = PM

Setting the Holiday Days

Press: **[1] [2] [*] Holiday Number [*] Month [*] Day [*]**

Holiday Number = 1-10

Month = 1-12

Day = 1-31

SPECIFICATIONS

MECHANICAL

Case dimensions: 6.45" W x 10.81" H x 3.74" D

ELECTRICAL

Voltage: 16 Volts AC or 12-24 Volts DC

Current: 650 mA AC typical, 1300 mA AC maximum

Backup Battery: Externally charged 12-24 Volt DC source

Outputs: Relay #1

Form "C" 3 Amps @ 30 Volts maximum

Relay #2

Form "C" 3 Amps @ 30 Volts maximum

Inputs: Two normally closed door sense/inhibit inputs

Two normally open request to exit inputs

RADIO

Frequency: 318 Mhz ± 500 KHz @ 23°C

RF 3db Bandwidth: 4 MHz Typical

Sensitivity: -97 dBm Minimum (-100 dBm Typical)

Encoding: Linear MegaCode® Format

ENVIRONMENTAL

Temperature: -22°F to 149°F (-30°C to 65°C)

Humidity: 5% to 95% non-condensing

DIMENSION DRAWING

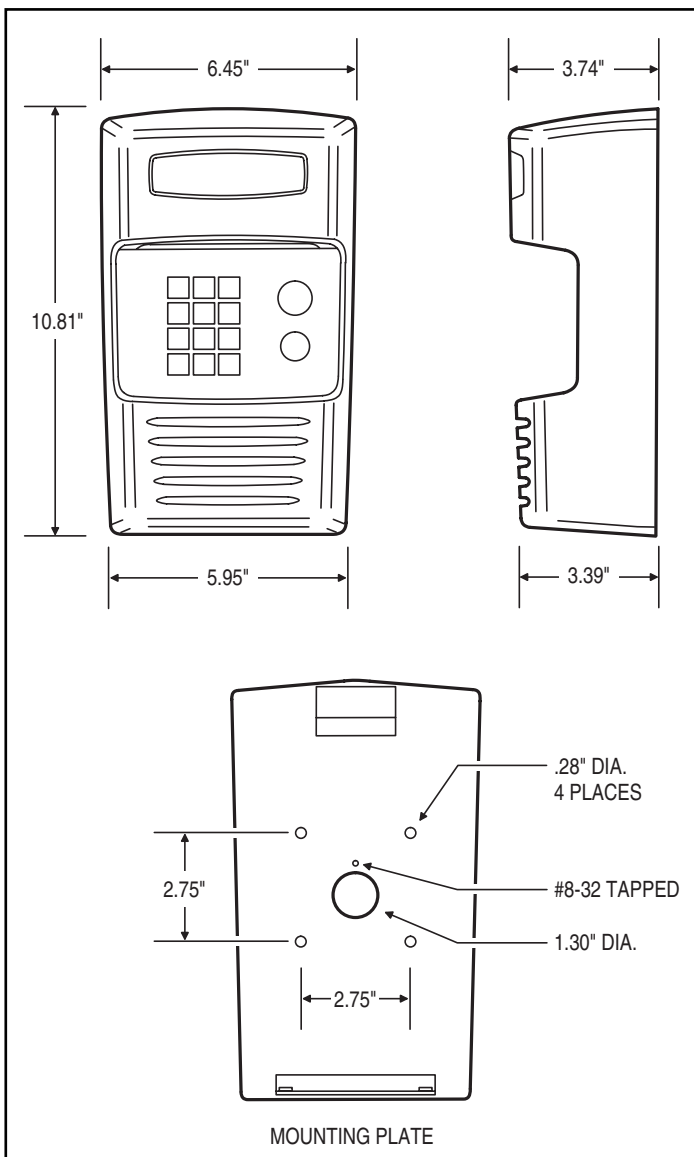

TROUBLESHOOTING

System will not go into programming mode

1. Wrong master code entered.

System completely dead

1. No power from transformer. Check voltage at RE-1 transformer terminals.
2. Verify that terminal blocks are firmly plugged into circuit board.

Buzz on speaker

1. Check for 24 volt AC power shorted to wiring conduit.
2. Check for telephone line shorted to ground.
3. Verify that telephone wires are twisted pair.
4. Verify that the RE-1 and the Telephone Bypass Module are connected to earth ground.
5. Check 16 VAC voltage at RE-1 transformer terminals.

Buzz on telephone line

1. Switch the Telephone Bypass Module to bypass. Connect line ring and tip to house ring and tip. Check line for buzz with test set.
2. Disconnect 16 VAC wires from terminal strip, if buzz goes away, one side of the transformer wires is grounded.
3. Check all connections for any shorts to ground.

Telephones in residence will not ring

1. Verify that the "Do Not Disturb" feature is not on while testing.
2. Verify that the Call Forwarding feature is not forwarding the calls at the time.
3. Check 16 VAC voltage at RE-1 transformer terminals.
4. Disconnect the house telephone line and connect a test telephone to the RE-1 house ring and tip terminals. See if the test telephone rings.

System will not answer an incoming call

1. Modem ring detect (PPN #33) disabled.
2. Calling pattern incorrect. Let telephone ring once, hang up, wait 10-30 seconds, then call again.

Call forwarding feature is not working

1. Incorrect phone number has been programmed (PPN #54)
 - ◆ **NOTE:** If you are programming the call forwarding feature as "on at all times", no programming entry is needed for the time zone (see example in PPN #54).

Entry code will not activate relay

1. Entry code not set up for proper relay (PPN #2).
2. Time zone is active for the relay.

Remote keypad does not work

1. Remote keypad address is not enabled (PPN #28).
2. Remote keypad relay is not selected (PPN #23).

Main or remote keypad will not activate a relay

1. Keypad is not assigned to a relay (PPN #23).
2. Entry code is not assigned to correct relay (PPN #2).

Gate does not open/close at programmed time

1. Time was not entered as **local** time (PPN #20).
2. Auto Daylight Saving Time disabled in area that observes daylight saving (PPN #46).
3. Automatic Door/Gate time zone is not properly programmed (PPN #53).

Relay #1 will not latch from the keypad

1. Add an entry code with the relay programmed as a 4 (latch relay #1, PPN #2).

PROGRAMMING WORKSHEET

TIME ZONES														
TIME ZONE	ACTIVE DAYS								START TIME			END TIME		
	SUN	MON	TUE	WED	THU	FRI	SAT	HOLIDAYS	HOUR	MINUTE	AM/PM	HOUR	MINUTE	AM/PM
1														
2														
3														
4														
5														
6														
7														

HOLIDAYS			
HOLIDAY	NAME	MONTH	DAY
1			
2			
3			
4			
5			
6			
7			
8			
9			
10			

SYSTEM PROGRAMMING			
FEATURE	PPN	DEFAULT	NEW VALUE
ENTRY CODE LENGTH	1	4	
TX LEFT BUTTON	8	RELAY #1	
TX RIGHT BUTTON	8	RELAY #2	
TX TOP BUTTON	8	RELAYS #1 & #2	
TX LOWER LEFT BUTTON	8	NONE	
TX LOWER RIGHT BUTTON	8	NONE	
RELAY #1 ON TIME	21	2 SECONDS	
RELAY #2 ON TIME	22	2 SECONDS	
MAIN KEYPAD ACTIVATES	23	RELAY #1	
REMOTE KEYPAD ACTIVATES	23	RELAY #2	
RELAY #2 ALARM FUNCTION	24	DISABLED	
MGT GATE EDGE TRANSMITTER	26	DISABLED	
RELAY #2 FUNCTION	27	2ND GATE	
REMOKE KEYPAD ADDRESS	28	3	
RELAY #1 SENSE OR INHIBIT	29	SENSE	
RELAY #2 SENSE OR INHIBIT	29	SENSE	
KEYPAD LOCKOUT COUNT	30	5 TRIES	
ANTI-PASSBACK TIME	31	DISABLED	
MAXIMUM VISITOR CALL RINGS	32	5 RINGS	
AUTOMATIC MODEM ANSWER	33	ENABLED	
DIALING METHOD	34	tone	
KEYPAD BEEPS	40	YES	
BEEP DURING RELAY #1	41	NO	
BEEP DURING RELAY #2	42	NO	
RELAY BEEP DURATION	43	1 SECOND	
VOICE SYNTHESIZER	44	ON	
VISITOR TALK TIME LIMIT	45	40 SECONDS	
DAYLIGHT SAVINGS TIME ADJUSTMENT	46	ENABLED	
CALL WAITING	50	ON	
DO NOT DISTURB MESSAGE	51	OFF	
AUTOMATIC GATE/DOOR OPEN TIME ZONES	53	NOT SET	
CALL FORWARDING TIME ZONE	55	NOT SET	
CALL FORWARDING	58	OFF	
TELEPHONE KEY FOR RELAY #1	71	1	
TELEPHONE KEY FOR RELAY #2	71	2	
TELEPHONE KEY FOR CALL WAITING SWITCH	71	6	
TELEPHONE KEY TO DISCONNECT VISITOR	71	9	
RESIDENCE INITIATED COMMAND PREFIX	72	##	
RESIDENCE PROGRAMMING PREFIX	72	###	

MASTER CODE	
CALL FORWARDING NUMBER	
ALTERNATE TELEPHONE NUMBER 1	
ALTERNATE TELEPHONE NUMBER 2	
ALTERNATE TELEPHONE NUMBER 3	

LINEAR LIMITED WARRANTY

This Linear product is warranted against defects in material and workmanship for twenty-four (24) months. The Warranty Expiration Date is labeled on the product. This warranty extends only to wholesale customers who buy direct from Linear or through Linear's normal distribution channels. Linear does not warrant this product to consumers. Consumers should inquire from their selling dealer as to the nature of the dealer's warranty, if any. **There are no obligations or liabilities on the part of Linear Corporation for consequential damages arising out of or in connection with use or performance of this product or other indirect damages with respect to loss of property, revenue, or profit, or cost of removal, installation, or reinstallation.** All implied warranties, including implied warranties for merchantability and implied warranties for fitness, are valid only until Warranty Expiration Date as labeled on the product. **This Linear Corporation Warranty is in lieu of all other warranties express or implied.**

All products returned for warranty service require a Return Product Authorization Number (RPA#). Contact Linear Technical Services at 1-800-421-1587 for an RPA# and other important details.

IMPORTANT WIRELESS INFORMATION

Linear radio controls provide a reliable communications link and fill an important need in portable wireless signaling. However, there are some limitations which must be observed.

- For U.S. installations only: The radios are required to comply with FCC Rules and Regulations as Part 15 devices. As such, they have limited transmitter power and therefore limited range.
- A receiver cannot respond to more than one transmitted signal at a time and may be blocked by radio signals that occur on or near their operating frequencies, regardless of code settings.
- Changes or modifications to the device may void FCC compliance.
- Infrequently used radio links should be tested regularly to protect against undetected interference or fault.
- A general knowledge of radio and its vagaries should be gained prior to acting as a wholesale distributor or dealer, and these facts should be communicated to the ultimate users.

FCC NOTICE

Changes or modifications not expressly described in this manual or approved by the manufacturer could void the user's authority to operate the equipment.

This equipment has been tested and found to comply with the limits for a Class B digital device, pursuant to Part 15 of the FCC Rules. These limits are designed to provide reasonable protection against harmful interference in a residential installation. This equipment generates, uses and can radiate radio frequency energy and, if not installed and used in accordance with the instructions, may cause harmful interference to radio communications. However, there is no guarantee that interference will not occur in a particular installation. If this equipment does cause harmful interference to radio or television reception, which can be determined by turning the equipment off and on, the user is encouraged to try to correct the interference by one or more of the following measures:

- Reorient or relocate the receiving antenna.
- Increase the separation between the equipment and receiver.
- Connect the equipment into an outlet on a circuit different from that to which the receiver is connected.
- Consult the dealer or an experienced radio/TV technician for help.

Linear  **ACCESS**