

212xt Wiring Diagrams and Specifications

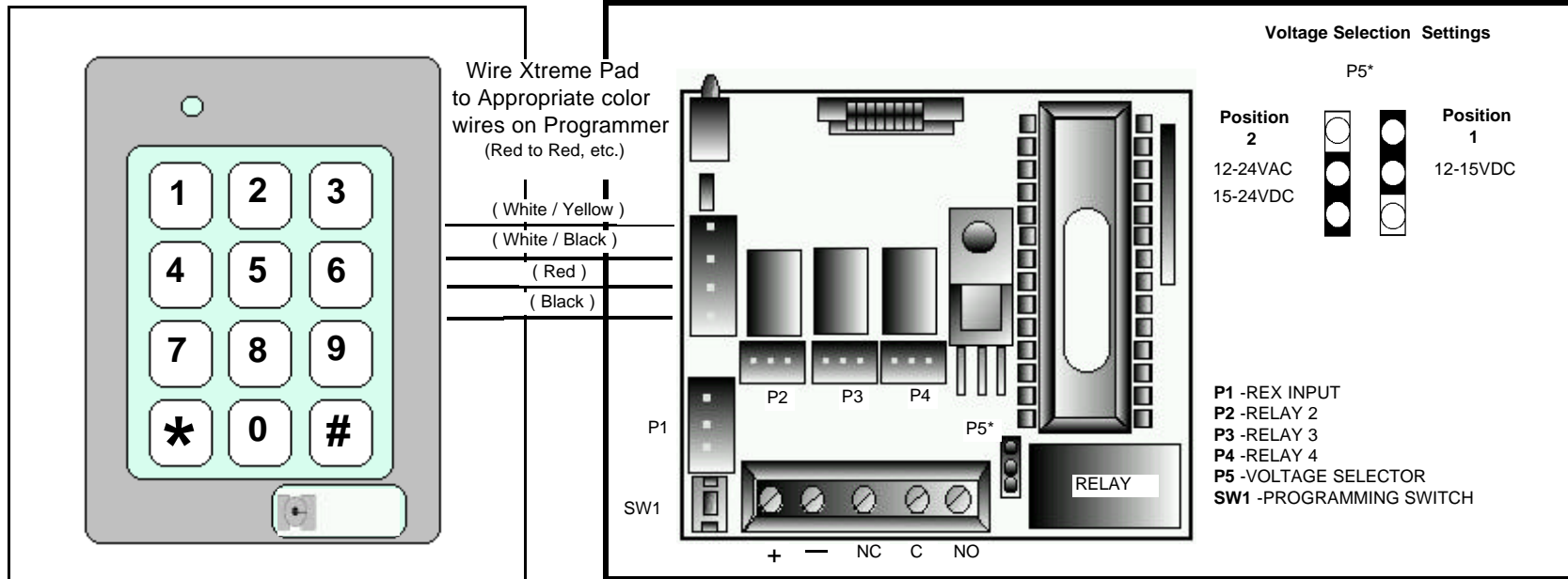

*P5 is the Voltage Selector. With the jumper in position one, 12-15vdc only operation is selected. With the jumper in position two 15-24vdc/12-24vac operation is selected.

Packing Checklist:

- Xtreme™ Keypad
- 212 XT Programming Controller
- Four Conductor Wire Harness (1)
- Three Conductor Wire Harness (4)
- Slotted Screws (4)
- Plastic Anchors (4)
- Machine Screws (2)
- 5/64 Allen Head Wrench (1)
- Tech Supp. With Warranty card
- Command & Control Features and Programming Guide

SPECIFICATIONS:

MECHANICAL:

XT CASE DIMENSIONS:
2.75"w x 4.50"h x 1.50"d

ENVIRONMENTAL:

TEMPERATURE:
-20°F TO 130°F (-28°C TO 54°C)

PROGRAMMER CASE DEMENSIONS:

2.75"w x 4.50"h x 2.50"d

ELECTRICAL:

VOLTAGE:
12-24 Volts AC/DC (selected by jumper)

CURRENT:

@12-24 Volts AC/DC- 20ma typical-150 max with all relays energized

OUTPUTS:

Main relay: 8 Amp, Form-C @ 24volts-10 AMP surge
Relays 2, 3, & 4 are Form C relays-1 AMP MAXIMUM

INTERNATIONAL



ELECTRONICS, INC.™

INTERNATIONAL ELECTRONICS, INC.
427 TURNPIKE STREET, CANTON, MA 02021 U.S.A.
800-343-9502, 617-821-5566 (FAX)617-821-4443

Visit our website for Access Control & Glassbreak information,
New Products, Specifications, Applications, Seminars, and Partners
@ WWW.IEIB.COM

6061170 REV 1.01

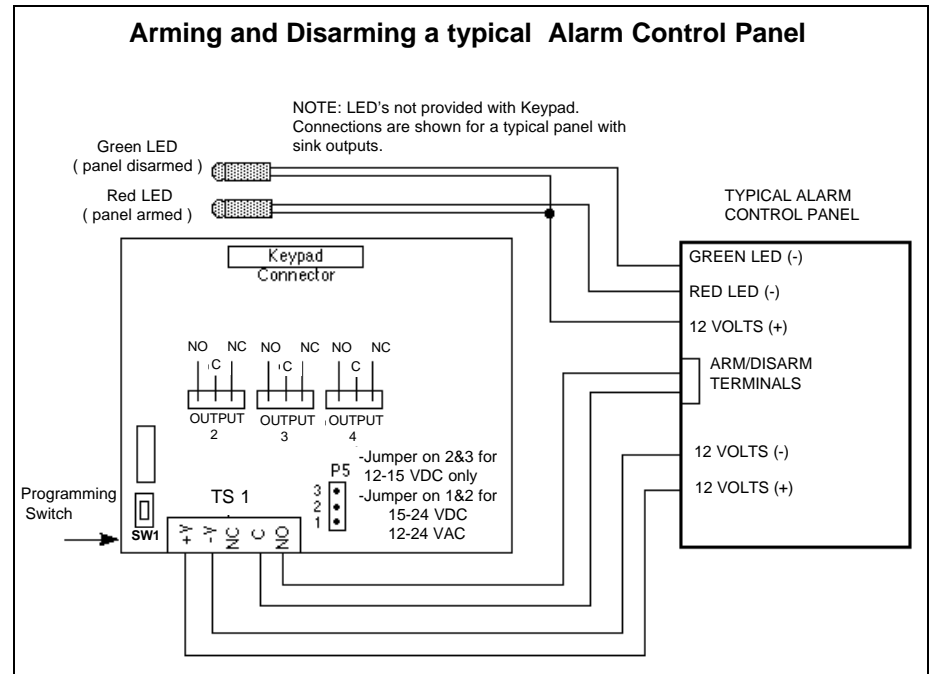
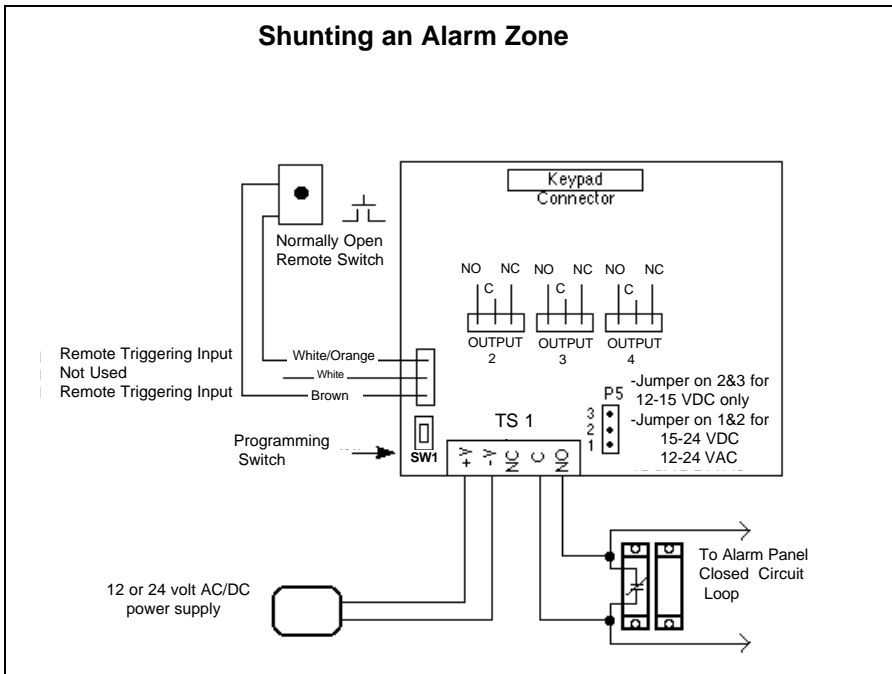
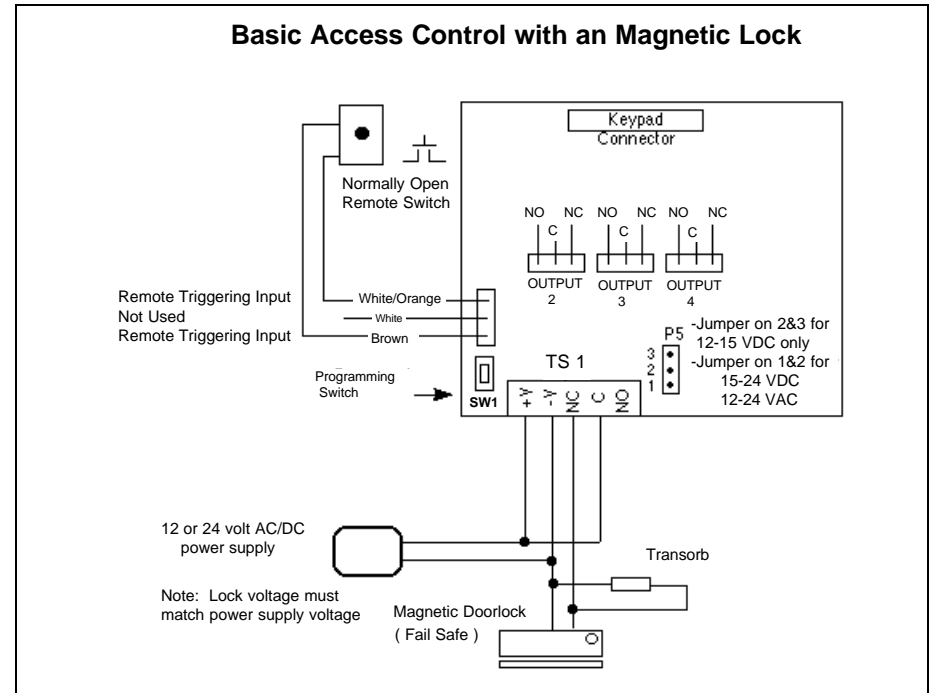
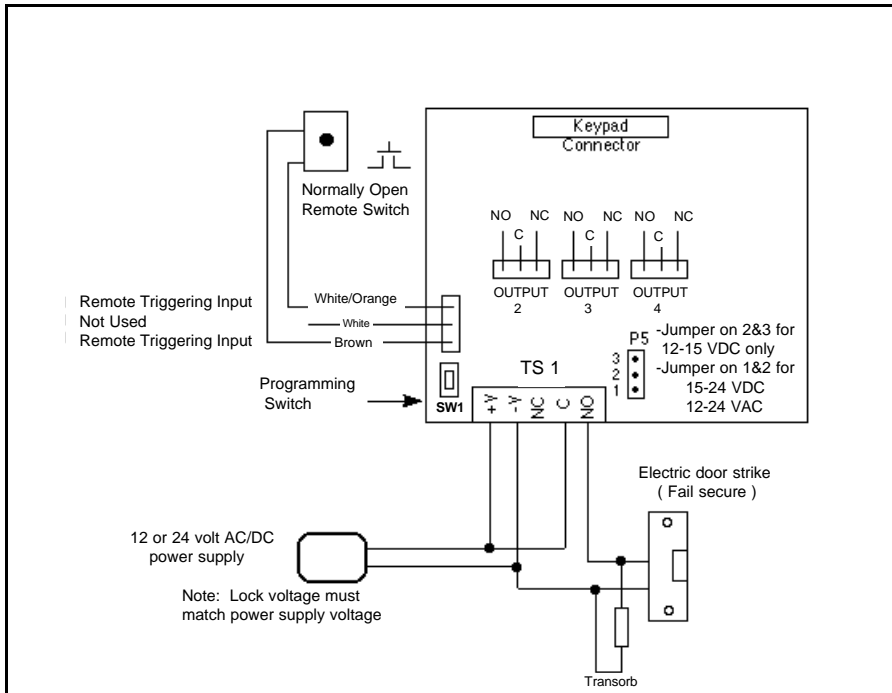

Auxiliary Outputs

The Extreme™ programming controller comes equipped with 3 auxiliary relay outputs and 3 internal timer circuits. The outputs can operate from 01-90 seconds, or you can program them to latch in the energized position until the same code, or another latch code is entered. These outputs maybe used to turn on or off, or shunt most devices after a valid code entry. The relays are form C relay and are rated to handle one (1) amp of current at either 12 volts or 24 volts, type AC or DC.

To incorporate this feature into your system, simply locate one of the five connectors, each one with three (3) wires, green, blue, and gray, located in the box with the Xtreme™ programming controller. With the controller powered down, unlatch the keypad from the plastic housing and slide the printed circuit board out of housing. With the circuit board out, you may now choose one of the exposed outputs as shown in **Diagram A**.

Wiring the Auxiliary Relays

Example: to a sounder

1. Connect the three conductor harness with the green, blue, and gray wire to the auxiliary output relay jack as shown in diagram A.
2. Connect green wire to V+ on sounder.
3. Connect blue wire to V+ from power supply.
4. Connect V- from power supply to V- on sounder.
5. Gray wire is not used.

Programming the Auxiliary Outputs

To program how long the output can operate for, Program as follows:

1. Enter programming mode. Press 99 # (master code) *
Verify controller is in programming. Yellow light should be flashing slowly.
2. Select the output that you want to program.

For output #2, press 12# (relay time)# 0# * *

For output #3, press 13# (relay time)# 0# * *

For output #4, press 14# (relay time)# 0# * *

*** Relay time must always be represented by two digits. for 5 seconds (05).**

To operate selected output(s) with a user code.

3. Verify that you are still in programming mode.
4. Press 59# (The output you choose: ie 2) # (user number) # (new code) * (repeat code) *
5. Exit programming mode by pressing the *

user number is where your code is stored in the memory of the keypad.

Xtreme™ CONTROL RELAY BOARD

DIAGRAM A

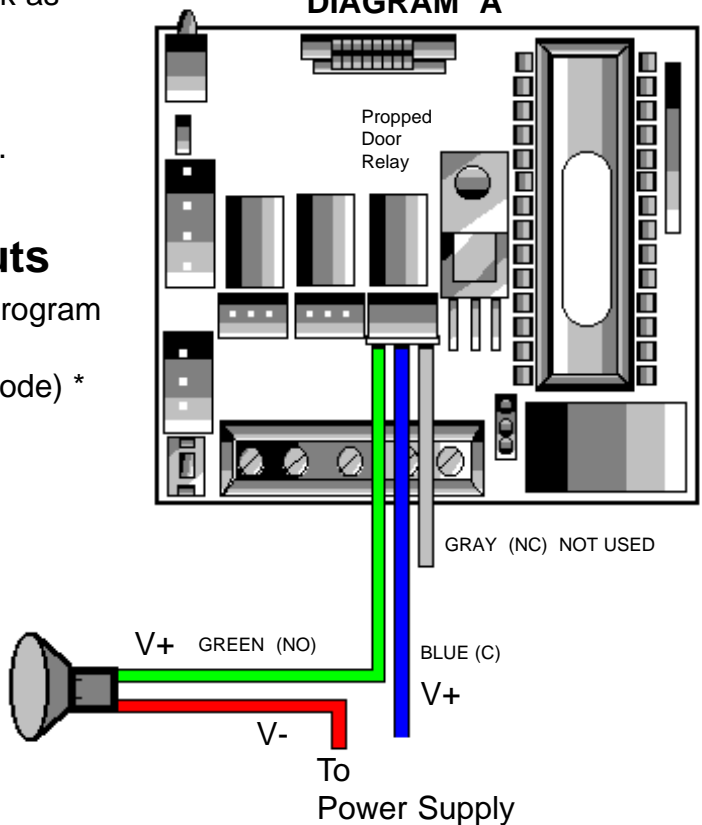

DIAGRAM B.

