

Model GSL

Industrial Gearhead Slide Door Operator Safety, Installation, and Service Manual

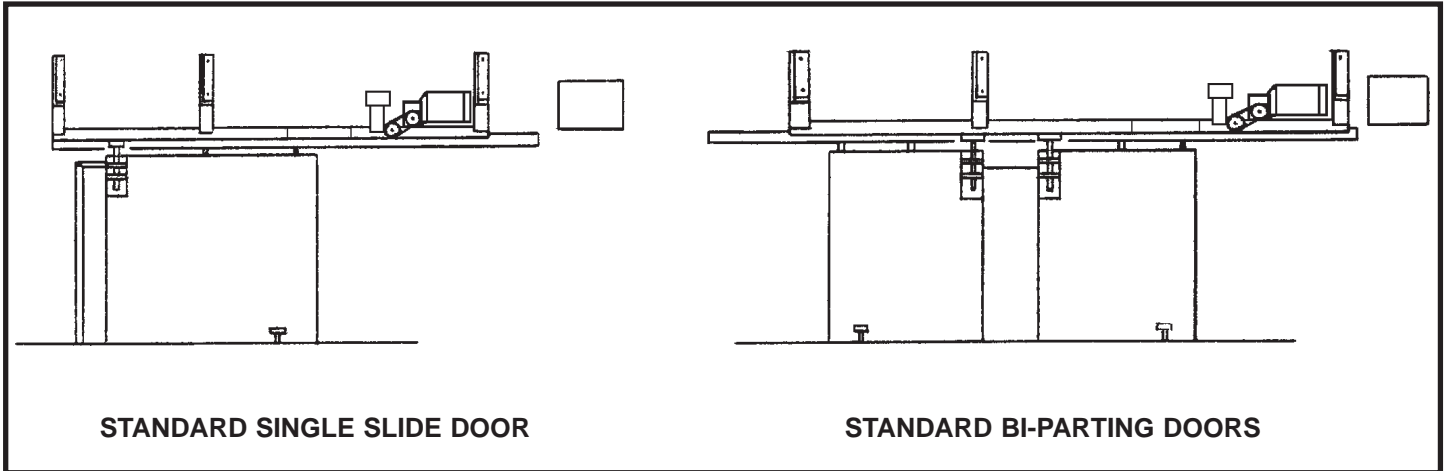

LINEAR requires use of an electric edge or photoelectric control for pedestrian protection on all automatic or remotely controlled door operators.

Linear[®]
Building On Innovation.

USA & CANADA (800) 421-1587 & (800) 392-0123
(760) 438-7000 - Toll Free FAX (800) 468-1340
www.linearcorp.com

Safety Information and Warnings

Read all of the following before beginning to install the Model GSL operator:

1. Read the green "SAFETY INSTRUCTIONS" sheet provided with the operator information. It's extremely important that the safety warnings and precautions be understood and followed by the installing contractor. Leave all instructions with the end user.
2. Do not attempt to operate the machine unless it is completely installed as instructed.
3. The installation must be made in a neat and professional manner, observing all rules of good workmanship and personal safety.
4. All electrical connections to the power supply must be made by a qualified and licensed electrician. All local and national codes must be observed.
5. A power-disconnect switch should be located within sight of the operator so that primary power can be turned off when necessary.
6. Do not open or remove enclosure covers unless you are qualified to service this equipment and the power is turned off. There are no user-serviceable parts inside.
7. Install enclosed warning signs so as to be visible to all persons passing near or through the door.
8. Operate the door only when it is in full view.
9. Do not permit children to play on or around the door.
10. Never reach through or around a door frame to operate the door controls.
11. Install all recommended safety equipment.

Features

Mechanical

- Fully assembled
- Heavy-duty right-angle gear reducer
- Adjustable torque limiter
- Magnetic disc brake
- Easily adjustable rotary limit switches
- Pull-pin disconnect for manual operation
- Fire door disconnect available standard on fire door operator

Electrical

- Continuous-duty industrial motor
- Available in all voltages
- 24V control circuit
- Contactor-type magnetic reversing starter
- Three-button control (OPEN–CLOSE–STOP)
- Delay on reverse
- Delay on reverse
- Adapted for radio controls and electric edge or photo-electric beam
- Adaptable for pull cords, key switches, time-delay systems, loop detectors

CAUTION

LINEAR STRONGLY RECOMMENDS USE OF AN ELECTRIC EDGE OR PHOTOELECTRIC CONTROL FOR PEDESTRIAN PROTECTION ON ALL AUTOMATIC OR REMOTELY CONTROLLED DOOR OPERATORS.

Children should never be allowed to play on, near, or around a motorized door. Any control devices should be placed so as to be inaccessible to small children.

The door should never be operated unless it is in visual sight of the user.

Warning signs must be installed on or near the door.

A pushbutton or keyswitch should not be installed within reach of the door or operator.

LIMITED ONE-YEAR WARRANTY

This electric operator is warranted for a period of one (1) full year from date of installation against defects in materials or workmanship. Any part, parts, or complete unit which fails because of such defects within this period shall, at the manufacturer's option, be repaired or replaced at no charge. The manufacturers will not be responsible for transportation and/or field service charges.

This warranty is in lieu of all other warranties, expressed or implied, and shall be considered void if visible evidence implies recommended installation procedures and maintenance instructions were not followed.

General Information

This LINEAR installation, maintenance, and parts manual has been developed to assist you in the installation and maintenance of your electric operator. It will also enable you to use the operator to its maximum efficiency. At the time this manual is issued to you, it covers only Model GSL. The parts lists and prints have been prepared so you can easily determine the parts contained in your operator.

The Model GSL operator is available in 1/2, 3/4, 1, or 1 1/2 HP, in all voltages and phases, with heavy-duty wormgear speed reducer, adjustable torque limiter, fully automatic and adjustable limit switches (rotary type), precision ball bearings permanently lubricated, heavy-duty pull-pin disconnect, and (optional) adjustable magnetic brake.

Operator Installation Instructions

Review the installation drawings included in this manual. They will give you a general idea of how the installation will look when finished. The drawing “**Guide for a Typical Installation,**” on page 4, defines terms used in the following sections. Also see drawing 2700-403 to assemble rail sections.

Check the Door(s)

It is important that the door(s) work smoothly and freely in both directions. The operator has plenty of power, but it is not intended to move a bound door.

Install Front Wall-Mounting Bracket

Single Slide Door. Position the front wall-mounting bracket so that the front end of operator is 9–12 inches beyond the edge of the door opening (see Figure 1). The bottom of the bracket should be approximately 10 inches above the opening, depending on type of door track (see Figure 2). Position the bracket as close as possible to the track. Be sure rollers will pass.

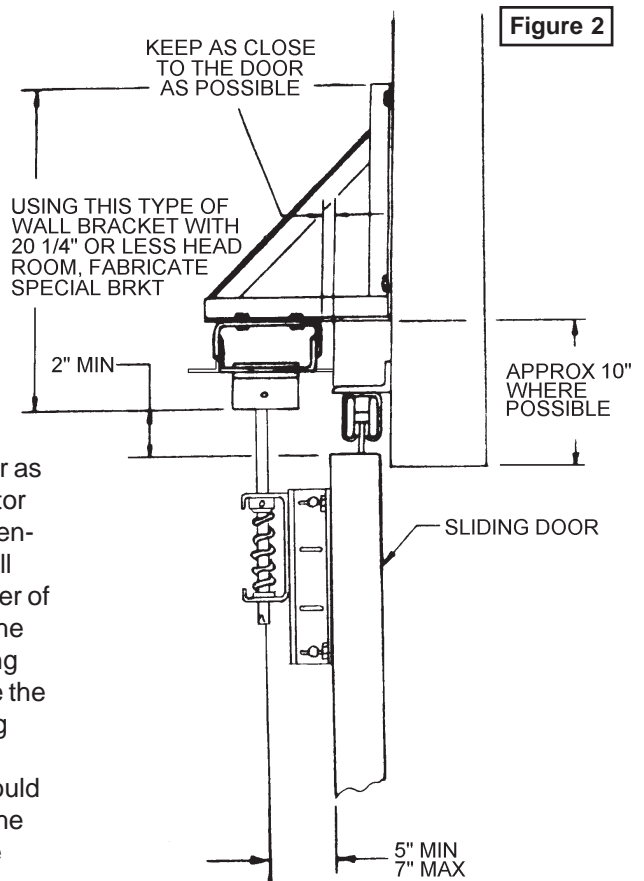
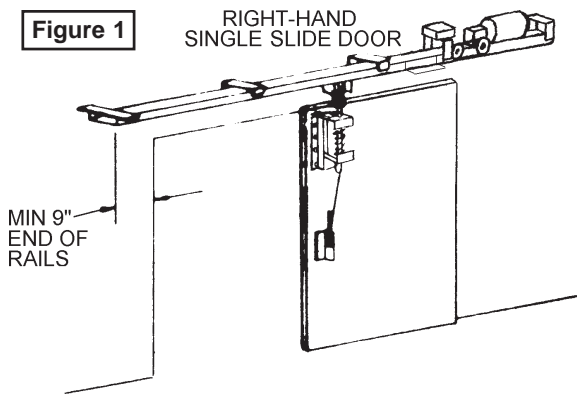

Bi-Parting Doors. With the operator’s travellers as close together as possible, measure the distance from the center of the front operator bracket to a position centered between the travellers. This is Dimension 1. Close the doors completely and, measuring along the wall above them, find the distance equal to Dimension 1 from the center of the opening (the meeting point of the doors). This distance from the center is the correct horizontal location for your front wall-mounting bracket. To allow for front-end bearing and traveller room, be sure the bracket is 19 inches or more beyond the edge of the door opening (see Figure 3). Vertical location of the front wall-mounting bracket depends on the type of track used. The bottom of the bracket should be approximately 10 inches above the opening (see Figure 2). If the track interferes, place the bracket above the track as close to the track as possible. Be sure rollers will pass.

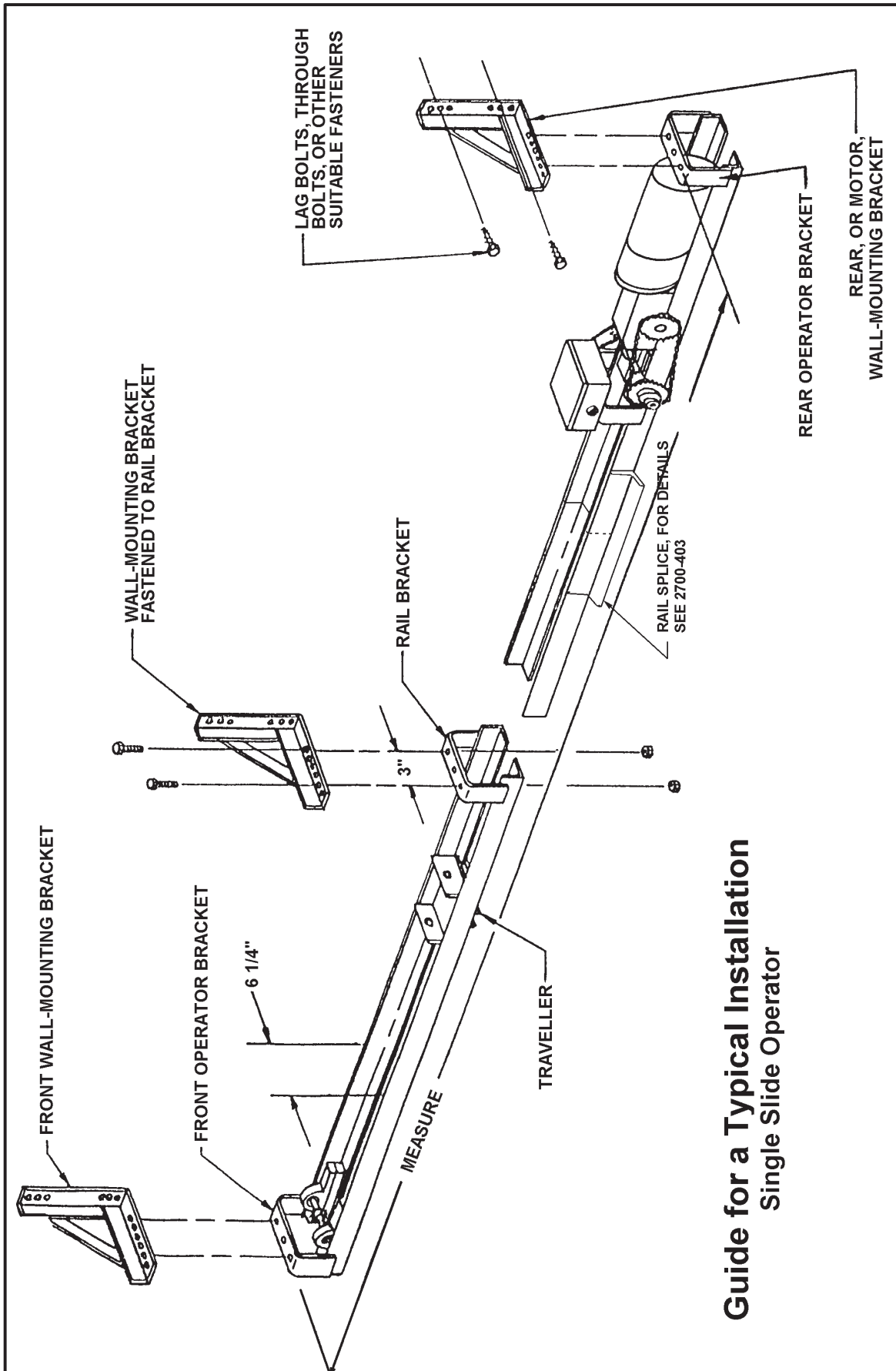

Guide for a Typical Installation Single Slide Operator

Install Rear (Motor) Wall-Mounting Bracket

Once the front wall-mounting bracket has been positioned, the rear, or motor-end, wall-mounting bracket can be positioned by one of two methods: (1) measure the distance from the front operator bracket to the rear operator bracket; or (2) lift the operator into place with the rear wall-mounting bracket attached, and mark hole locations on the wall. The operator must be level, which means all wall-mounting brackets should be positioned the same distance above the opening or track.

Install Middle Wall-Mounting Bracket(s)

Your operator was shipped with the number of middle wall-mounting brackets necessary for the door width specified in your order. Be sure to install all of the middle wall-mounting brackets supplied.

Install Door Bracket(s) and Disconnect Mechanism(s)

Standard Door Bracket for Single Slide Door. With the door closed and the traveller within 2–3 inches of the front end of the operator, position the door bracket so the disconnect pin engages the pocket of the traveller (see Figure 2).

Standard Door Brackets for Bi-Parting Doors. With the doors fully closed and the travellers in a corresponding position, place the door brackets so the disconnect pins engage the pockets of the travellers.

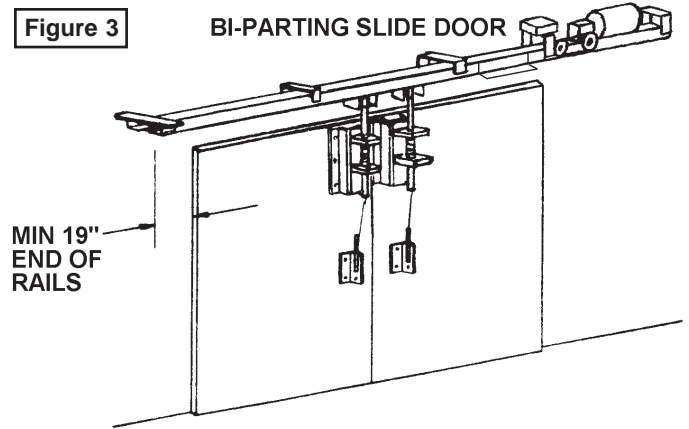

IMPORTANT NOTE

On either a single slide door or bi-parting doors, a door bracket should not be closer to the top of the door than 1 inch. Through bolts should be used (see Figure 4). The door bracket disconnect pin is designed to be extended upward on installations where the operator cannot be hung low enough for normal engagement. To extend the disconnect pin, merely loosen the set screw in the set collar and push the pin upward. The door bracket is made with adjustment slots on the sides of the channel, allowing for adjustment of the disconnect pin to align with the center of the traveller. The pin should be as close as possible to the center of the traveller.

Standard Door Bracket Disconnect Lever. The door bracket disconnect pin should have a disconnect lever attached to the door directly below the door bracket, 4–5 feet above the floor. The disconnect lever bracket should be attached to the disconnect lever as shown in Figure 5. Be sure the cable is cut and attached to the lever so that the pin is disengaged from the traveller when the lever is down.

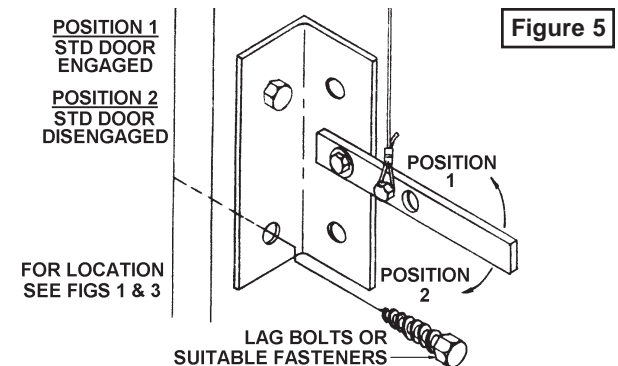
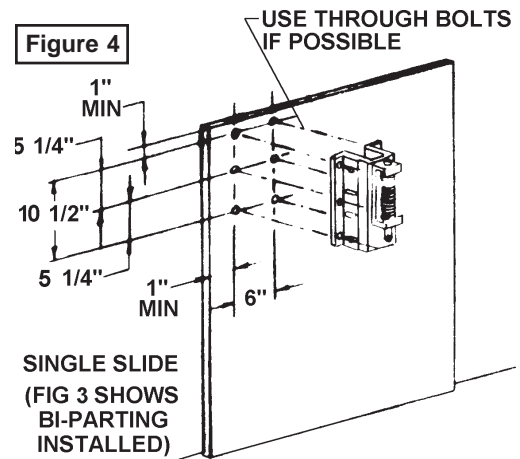

Bracket and Disconnect Installation for Fire Door. The LINEAR fire door disconnect bracket has been designed to automatically release the door from the operator. Figure 6 shows a typical installation. When installed properly, a fused-link cable system of the type shown separates upon detection of excessive heat, allowing the horizontal cable located across and above the door opening to retract into either a counterweight system or a spring-loaded cable reel. As the cable retracts, a triggering device attached to the cable (typically a bull ring or repair link) is pulled into contact with the trigger mechanism on the door bracket, causing a pivot bar to shift sideways and drop the spring-loaded disconnect pin and allowing the door to close. Follow Figure 6 for additional information about installing this type of mechanism.

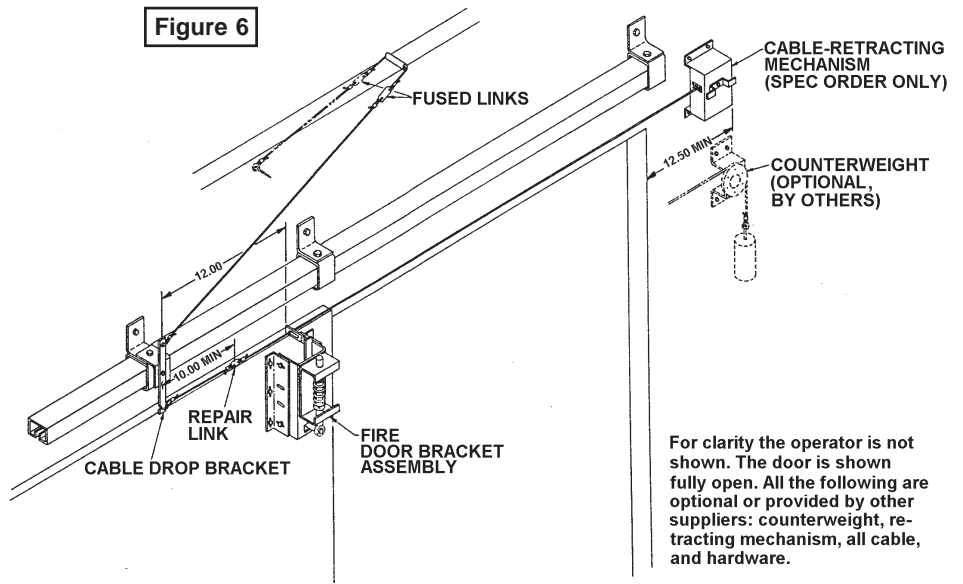

IMPORTANT

A. Power supply must be of correct voltage and phase.
B. Always disconnect power from the operator before servicing.
C. Keep clear of the door during operation.

Electrical Instructions

A complete wiring diagram can be found inside the operator’s controller cover. Voltage supplied should correspond to the voltage specified on the operator name plate, and power should be brought into the operator with no smaller than No. 12 wire. For proper wire gauge, refer to “**Wiring Specifications,**” on Page 14. Electrical power must be ample and not taken from an overloaded line, as faulty operation will result.

This operator is supplied with a 3-button control station (OPEN–CLOSE–STOP) accompanied by a precautionary sign warning against starting the door(s) in motion unless the doorway is cleared. It is vital that the 3-button station be mounted within sight but out of reach of the door and that the warning sign be mounted adjacent to the 3-button station.

<p>The 3-button station must be connected so the STOP circuit between terminals #2 & #4 is not bypassed. Also, if additional 3-button stations are to be connected, the STOP buttons must be wired in series.</p> <p>NOTE: A STOP button must be used when the installation has radio controls or a single button.</p>	<p style="text-align: center;"><u>Desired Function</u></p> <p style="text-align: center;">OPENING DEVICE</p> <p style="text-align: center;">STOP</p> <p style="text-align: center;">CLOSE</p> <p style="text-align: center;">OPEN & CLOSE</p> <p style="text-align: center;">SAFETY TO REVERSE</p> <p style="text-align: center;">24VAC POWER</p>	<p style="text-align: center;"><u>Connecting Terminals</u></p> <p style="text-align: center;">#1 & #4</p> <p style="text-align: center;">#2 & #4</p> <p style="text-align: center;">#3 & #4</p> <p style="text-align: center;">#4 & #5</p> <p style="text-align: center;">#1 & #6</p> <p style="text-align: center;">#2 & #10</p>
--	---	---

Important Notice for NEMA 12 Operators

NOTE: Not applicable to UL listed fire door operators.

1. The NEMA 12 control panel, if supplied with this operator, must be wired to the operator junction box in accordance with local and national electrical codes.
2. Two conduits will be required between the NEMA 12 control panel and the operator junction box. One must be provided for low-voltage control wires, and the second box for high-voltage wires.

- Incoming power supply (double-check circuit drawing for proper voltage and phase) connects to wire leads provided inside a special junction box within the NEMA 12 control panel.
- Grounding Requirement.** The green grounding leads in the operator junction box and the NEMA 12 control panel must be tied together. Then the tied-together leads are to be connected to earth ground.

**DISCONNECT POWER FROM THE OPERATOR
BEFORE MAKING ADJUSTMENTS.**

Adjustments

Limit Switch Adjustment

- Secure all electrical power connections L1 and L2 on single phase and L1, L2, and L3 on three phase. Turn power on.
- With the door in halfway position, touch the OPEN button. If the door closes, depress the STOP button immediately. On three-phase operators, reverse any two of the three power connections (L1 and L2).
- Depress the CLOSE button. If the door closes, the operator should stop when the close limit nut engages the close limit switch. Press the STOP button and reverse the limit switch wires.
- Adjust limit nuts by releasing the detent plate and turning the nuts in the desired direction (Figure 7). A complete turn allows the door to move 4–6 inches. Be sure the detent plate is properly locked into both limit nuts when adjustment is complete.

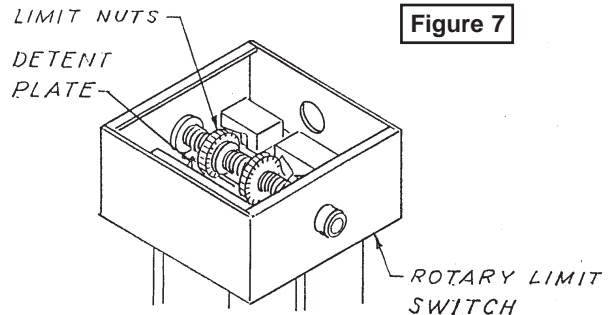

Figure 7

REMOVE COVER. DEPRESS THE DETENT PLATE, AND ROTATE THE LIMIT NUTS IN THE DESIRED DIRECTION. BE SURE THE DETENT PLATE IS PROPERLY LOCKED INTO BOTH LIMIT NUTS AFTER ADJUSTMENT IS COMPLETED. REPLACE THE COVER.

Torque Limiter Adjustment

The torque limiter is set light at the factory. **It must be adjusted during installation and checked on a regular basis.** Before adjusting the torque limiter, make sure the door is in good working condition. One person should be able to move the door by hand. Be certain the door moves freely and without binding throughout its entire travel.

NOTE: The torque limiter should be set tight enough so that when the operator starts the torque limiter does not slip, but loose enough to slip if the door is obstructed.

- Bend the locking tabs away from the adjustment nut.
- To increase the output,** turn the adjustment nut clockwise one flat, or 1/6 turn, at a time until desired output is obtained.

WARNING: Do not overtighten. The torque limiter must slip if the gate is obstructed.

To reduce the output, turn the adjustment nut counterclockwise one flat, or 1/6 turn, at a time until desired output is obtained.

NOTE: A properly adjusted torque limiter will not slip during normal operation.

- Bend the locking tabs up to lock the adjustment nut.

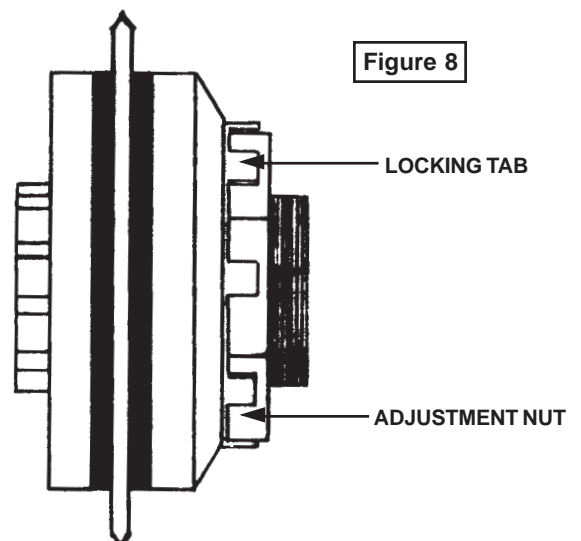

Figure 8

Drive Chain Adjustment

The main drive chain is the chain that is attached to the traveller in the rail assembly. It is attached to the traveller with chain-adjustment pins. The slack in the chain should be taken up as normal chain stretch occurs. While it is important that chain slack not be excessive, it is equally important that the drive chain not be so taut that premature wear occurs. If the chain jumps and clicks as it goes around the drive sprocket, it is probably too tight.

**DISCONNECT POWER FROM THE OPERATOR
BEFORE SERVICING!**

Maintenance

General

LINEAR door operators are designed for many years of trouble-free operation and, under normal operating conditions, will require only minimal maintenance.

To ensure that your unit is ready for operation at all times—and to preclude serious damage or failure—inspect the unit systematically. Proper adjustments and lubrication should be made as recommended.

Lubrication

Bearings. All bearings are oiltite and are permanently lubricated.

Motor. Motors have sealed ball bearings and do not require further lubrication. If bearing noise develops after several years of operation, bearings should be replaced.

Drive Chain and Sprocket. Drive chains and sprockets should never be greased or heavily oiled. However, drive chains should occasionally be wiped down with an oily cloth.

Rails. Rails do not require lubrication, but wiping them occasionally with an oily cloth will help increase their life.

12-Month Preventive Maintenance

1. Check torque limiter for correct tension every 12 months.
2. Inspect torque limiter disc for wear every 12 months.
3. Check limit switches for adjustment and wear.
4. See that all nuts and bolts are tight.
5. If your unit has the optional magnetic brake, check brake for proper setting. Do not overtighten. Brake disc must run free when brake is engaged.

Troubleshooting

Operator fails to work:

1. Overload kicked out. Disconnect power before opening control box. Reset overload.
2. Main power disconnected at master distribution panel. Reconnect power.
3. (Optional) Secondary fuse blown. Replace!

Motor operates but the door does not move:

1. Check to see that torque limiter is engaged.

2. Make sure that torque limiter is adjusted properly. (Factory settings are very light.)
3. Be sure that chain is not broken.
4. Make sure that track is not covered with oil or grease.
5. Check for broken or disconnected drive chain.
6. Check for burned out brake solenoid. (Remove inspection cover.)
7. Check for stuck limit switch.

Ordering Replacement Parts

Use the numbers shown in the lists on the following pages to order all replacement parts.

1. Supply the serial number of your operator.
2. Specify the quantity of pieces needed.
3. Order by part number and name of part.
4. State whether to ship by freight, truck, parcel post, UPS, or air express.
5. State whether transportation charges are to be prepaid or collect.
6. Specify name and address of person or company to whom parts are to be shipped.
7. Specify name and address of person or company to whom the invoice is to be sent.

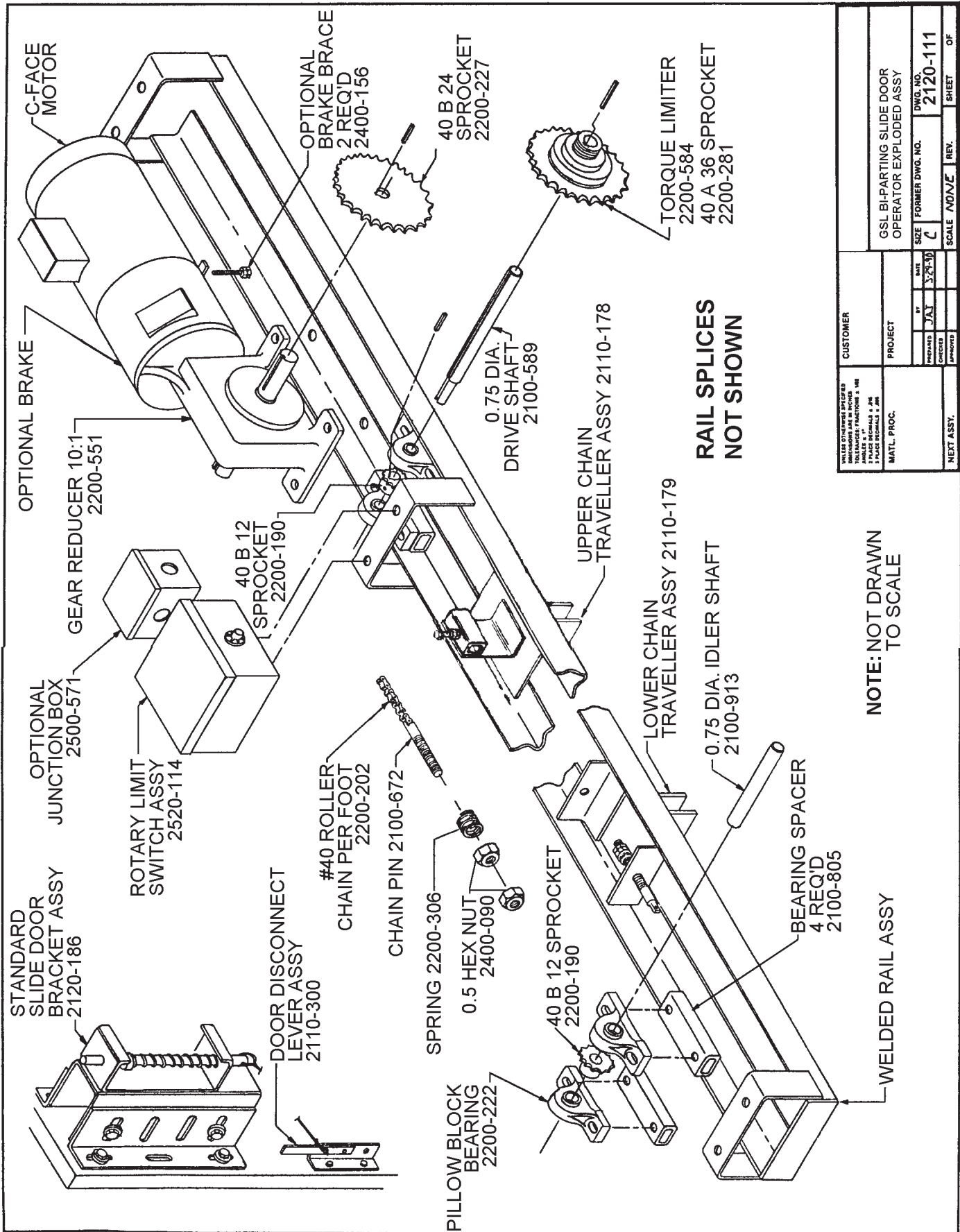

UNLESS OTHERWISE SPECIFIED DIMENSIONS ARE IN INCHES ANGLES IN DEGREES SURFACE FINISH IS AS SHOWN UNLESS OTHERWISE SPECIFIED

CUSTOMER	GSL BI-PARTING SLIDE DOOR OPERATOR EXPLODED ASSY		
PROJECT	SIZE	FORMER DWG. NO.	DWG. NO.
BY	C	2120-111	2120-111
PREPARED	JAJ	DATE	3-7-90
CHECKED		SCALE	AS SHOWN
APPROVED		REV.	OF
NEXT ASSY.			

NOTE: NOT DRAWN TO SCALE

**Model GSL
Parts List #123 (Mechanical)
LINEAR Drawings #2120-235 and #2120-111**

<u>Part No.</u>	<u>Description</u>	<u>Part No.</u>	<u>Description</u>
2200-551	Gear Reducer, 10:1		<i>Rail Assemblies (call factory)</i>
2100-589	Drive Shaft, 3/4"	2120-384	For 14' Single Slide Door
2100-913	Idler Shaft, 3/4"	2120-385	For 14' Bi-Parting Door
2200-584	Torque Limiter, 3"		
2200-222	Pillow Block Bearing, 3/4"	2110-159	Wall-Mounting Bracket
2100-805	Bearing Spacer	2100-1855	Rail Splice
2200-860	#40 Chain, 29 Links		
2200-006	#40 Master Link		<i>GSL-S (Single Slide with Standard Door Disconnect) also has</i>
2200-654	#48 Roller Chain, per foot	2120-186	Standard Pull-Pin Disconnect Assembly (1)
2200-010	#48 Master Link	2100-646	Adjustable U-Bracket
2100-672	Chain Pin	2100-716	Disconnect Pin Bracket
2200-306	Spring	2100-691	Disconnect Pin, 1"
2500-033	Standard 3-Button Station	2200-015	Set Collar, 1"
		2200-265	Spring
2520-114	Rotary Limit Box Assembly		
2500-764	Limit Switch	2100-300	Disconnect Lever Assembly (1)
2100-057	Standard Limit Shaft	2100-560	Lever Bracket
2200-030	Limit Nut	2100-561	Lever
2100-261	Detent Plate		
2110-162	Limit Box Enclosure with Cover	2110-179	Complete Single Slide Traveler Assembly
2100-773	Limit Box Cover only		
2200-029	Flange Bearing, 1/2" ID		<i>GSL-P (Bi-Parting with Standard Door Disconnect) also has</i>
2400-029	Push-On Nut	2120-186	Standard Pull-Pin Disconnect Assembly (2)
		2100-300	Disconnect Lever Assembly (2)
2500-2192	Optional C-Face Brake, 115/230V	2110-178	Complete Upper Chain Traveler Assembly
2500-2193	Optional C-Face Brake, 460V	2110-179	Complete Lower Chain Traveler Assembly
2500-571	Optional NEMA Junction Box		
			<i>GSL-FS (Single Slide with Fire Door Disconnect) also has</i>
	<i>Sprockets</i>	2120-168	Fire Door Disconnect Assembly (1)
2200-190	Idler and Drive, 40-B-12, 3/4" bore	2110-191	U-Bracket
2200-281	Torque Limiter, 40-A-36, 2" bore	2100-716	Disconnect Pin Bracket
2200-227	Gear Reducer, 40-B-24, 1" bore	2100-558	Disconnect Pin, 1"
2200-277	Drive Shaft Limit Sprocket, 48-B-10, 5/8" bore	2200-015	Set Collar, 1"
2200-008	Limit Box, 48-B-10, 1/2" bore	2200-265	Spring
		2110-179	Complete Single Slide Traveler Assembly
			<i>GSL-FP (Bi-Parting with Fire Door Disconnect) also has</i>
2500-2157	1/2 HP, 115/230V, 1 Phase	2120-168	Fire Door Disconnect Assembly (2)
2500-2158	3/4 HP, 115/230V, 1 Phase	2110-178	Complete Upper Chain Traveler Assembly
2500-2159	1 HP, 115/230V, 1 Phase	2110-179	Complete Lower Chain Traveler Assembly
2500-1603	1/2 HP, 208/230/460V, 3 Phase		
2500-1604	3/4 HP, 208/230/460V, 3 Phase		
2500-1605	1 HP, 208/230/460V, 3 Phase		

**Model GSL
Parts List #123 (Electrical)**

<u>Part No.</u>	<u>Description</u>	<u>Part No.</u>	<u>Description</u>
2520-188	Complete Controller, 115V, 1 Phase (WD #2600-218)	2520-195	Complete Controller, 208/230V, 1 Phase (WD #2600-219)
2110-150	Enclosure, NEMA 1	2500-767	Transformer, 230/24V, 75VA
2500-2084	Contactor, 4-Pole	2500-543	Relay, 230V, 3PDT
2500-766	Transformer, 115/24V, 75VA	2520-223	Complete Controller, 208/230V, 3 Phase
2500-185	Terminal Strip, 13-142	2520-196	Complete Controller, 460V, 3 Phase (WD #2600-220)
2500-774	Terminal Strip, 3-142	2500-767	Transformer, 230/24V, 75VA (208/230V)
2500-542	Relay, 120V, 3PDT	2500-768	Transformer, 460/24V, 75VA (460V)
2500-541	Relay, 24VAC, 3PDT	2500-541	Relay, 24VAC, 3PDT

**STANDARD DOOR DISCONNECT
2120-186**

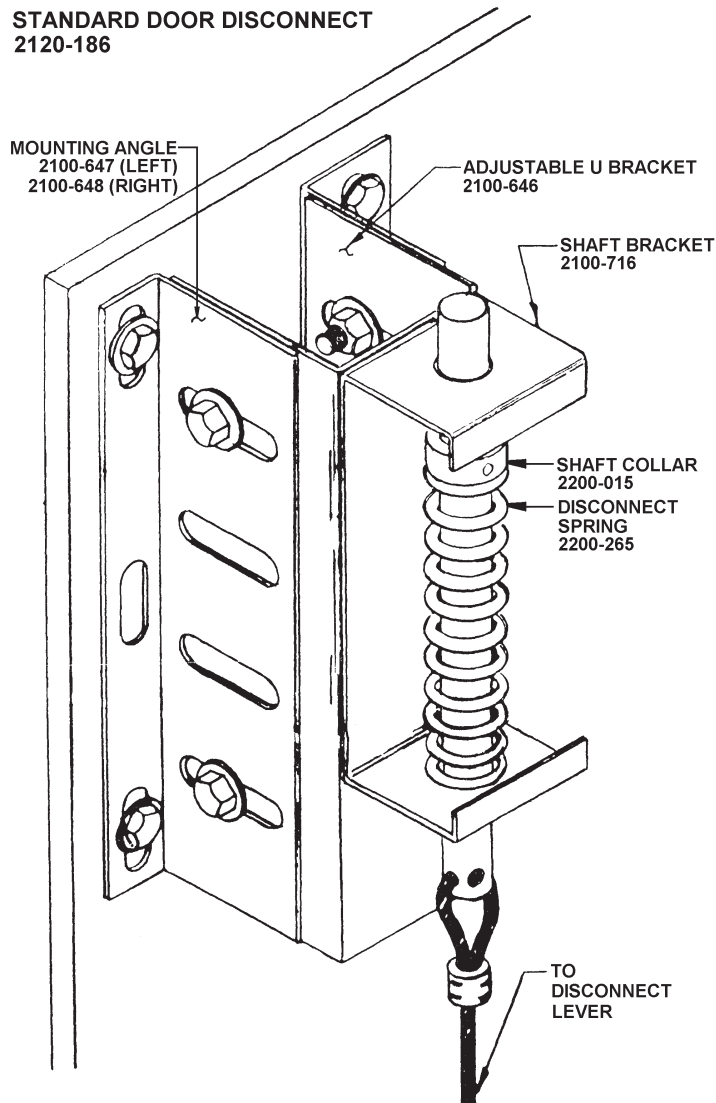

**FIRE DOOR DISCONNECT
2120-168**

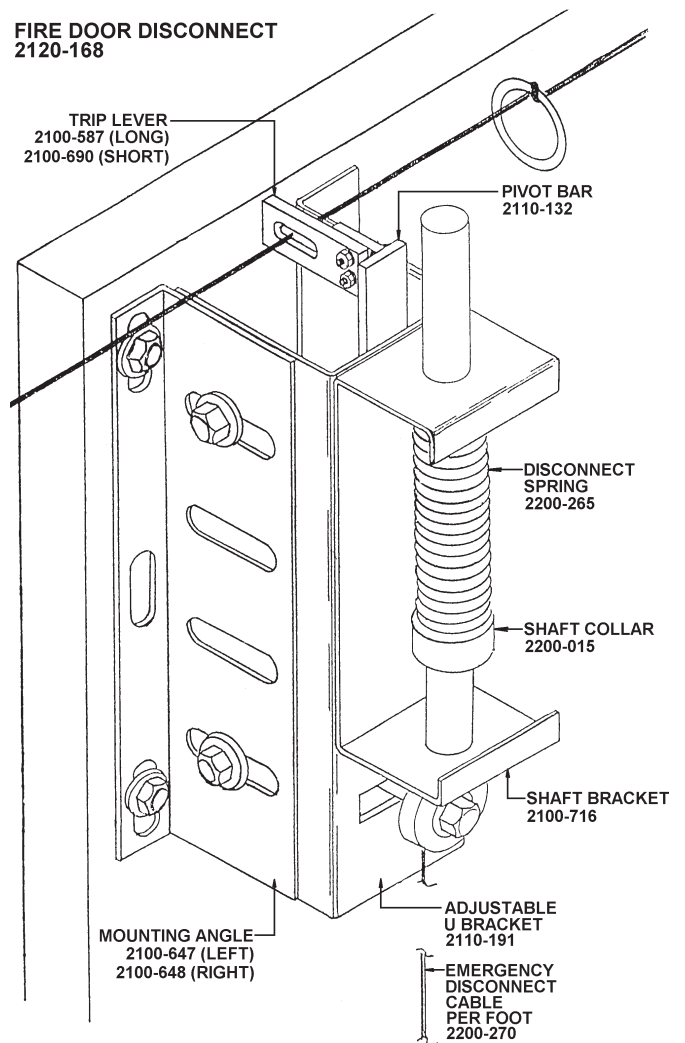

Wiring Specifications

1. Select from the chart at right the section corresponding to the phase, voltage, and horsepower of your operator.
2. The distance shown on the chart is measured in feet from the operator to the power source. **DO NOT EXCEED THE MAXIMUM DISTANCE.**
3. When large-gauge wire is used, a separate junction box (not supplied) may be needed for the operator power connection.
4. Select the gauge for control wiring from the top chart below. If a greater distance is required, our remote station interface is suggested. Call the factory.
5. Wire run calculations are based on the National Electrical Code, Article 430, allowing 5 percent voltage drop.
6. Supply voltage must be within 10 percent of the operator rating under load conditions.
7. Connect power in accordance with local codes.
8. The wire tables are based on standard copper wire. Wire insulation must be suitable to the application.

NOTE: If the power run is over 500 feet, consult your power utility company about possible power drops overhead or underground.

USE COPPER WIRE ONLY

Power Wiring								
Volts & HP	Max Distance (ft)		Wire Gauge	Volts & HP	Max Distance (ft)		Wire Gauge	
	Single Unit	Dual Unit			Single Unit	Dual Unit		
Single Phase	115V	120	60	12	208V	475	240	
		190	95	10	230V	760	380	
		305	150	8	1200	600	8	
	1/3HP	485	240	6	1/3HP	1915	960	6
		115V	125	60	12	208V	370	185
			200	100	10	230V	585	295
	315		160	8	935	465	8	
	1/2HP	500	250	6	1/2HP	1485	740	6
		115V	65	30	12	208V	260	130
			105	50	10	230V	415	205
	165		80	8	665	330	8	
	3/4HP	265	130	6	3/4HP	1055	600	6
115V		55	30	12	208V	225	115	
		85	45	10	230V	360	180	
	140	70	8	570	285	8		
1HP	225	115	6	1HP	910	455	6	
	Three Phase	208V	650	325	12	460V	2850	1425
		230V	1035	515	10	4535	2265	10
1645			825	8	7210	3605	8	
2615			1310	6	1/3HP	11465	5730	6
1/3HP		208V	620	305	12	460V	2705	1350
		230V	985	490	10	4305	2150	10
			1565	780	8	6850	3425	8
2485			1240	6	1/2HP	10895	5445	6
1/2HP		208V	440	220	12	460V	1935	965
		230V	700	350	10	3075	1540	10
			1115	558	8	4890	2445	8
1775			885	6	3/4HP	7780	3890	6
3/4HP	208V	345	170	12	460V	1595	795	
	230V	545	275	10	2535	1265	10	
		870	435	8	4030	2015	8	
1380		690	6	1HP	6405	3205	6	
1HP	208V	235	120	12	460V	1040	520	
	230V	380	190	10	1655	825	10	
		600	300	8	1 1/2	2635	1315	
955		480	6	HP	4190	2095	6	
2HP	208V	180	90	12	460V	795	400	
	230V	290	145	10	1265	635	10	
		460	230	8	2015	1005	8	
730		365	6	2HP	3205	1600	6	

Control Wiring		
Volts	Max Distance (ft)	Wire Gauge
24V	250	14
	350	12
Over 350 ft, see interface chart.		

Control Wiring w/ Interface		
Volts	Distance Over (ft)	Wire Gauge
24V	350	14

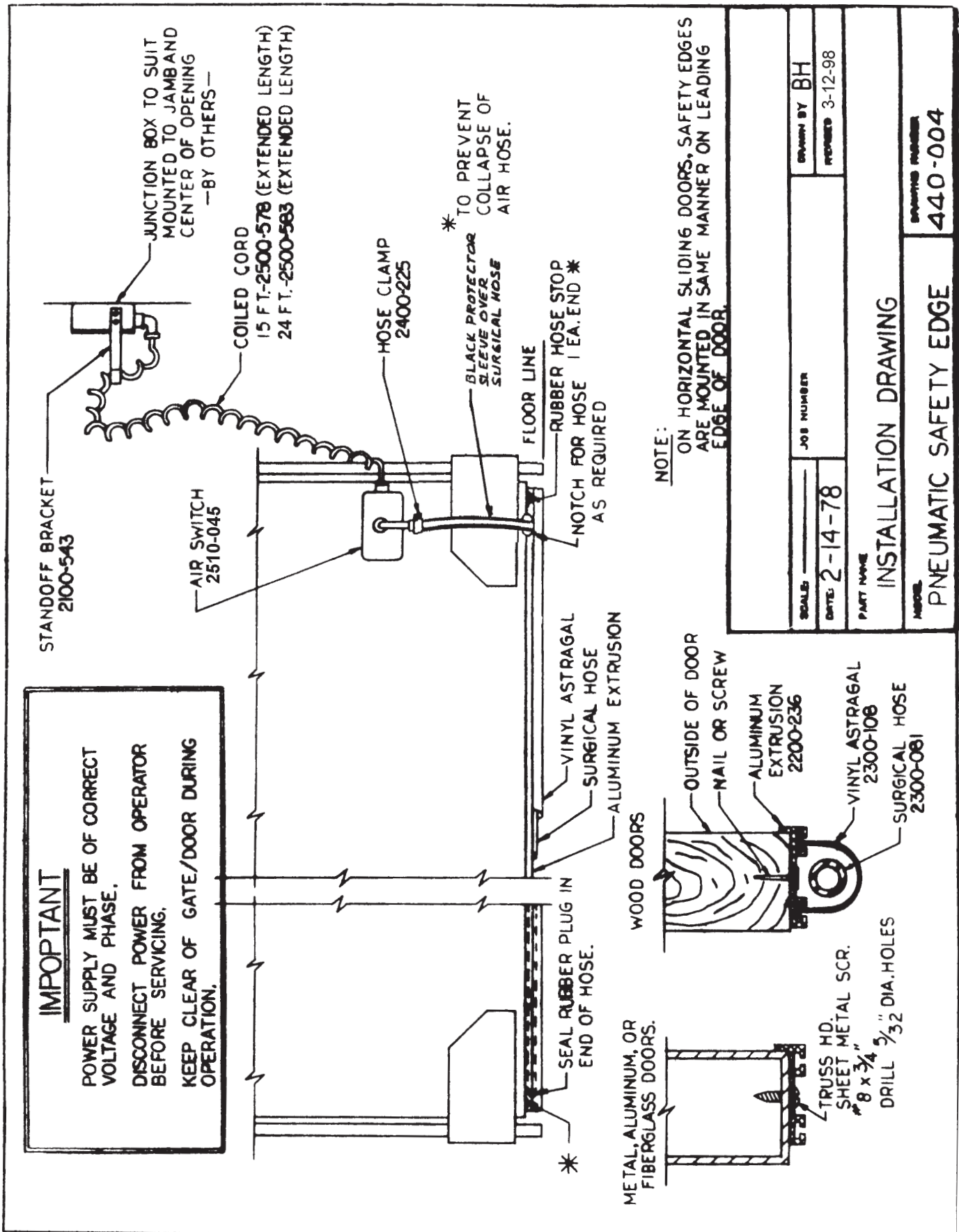

MOUNTING INSTRUCTIONS FOR ELECTRICALLY OPERATED REVERSING EDGE

DO NOT PAINT ANY PART OF THE REVERSING EDGE

LEADING EDGE OF WOODEN DOORS - 2 METHODS :

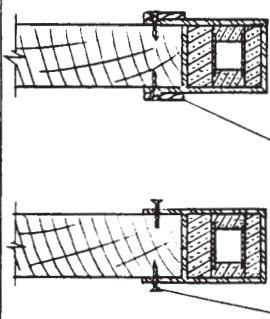

DRIVE SCREWS OR SCREWS - IF DESIRED - BY OTHERS

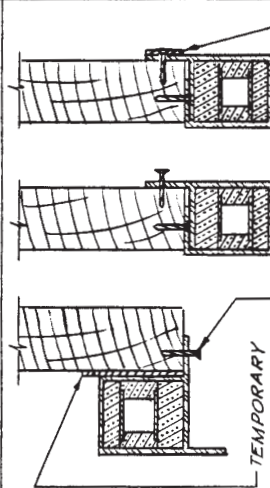

TEMPORARY SPACER STRIP OF CORRECT THICKNESS - BY OTHERS

"U" SHAPED REVERSING EDGE METHOD "A"

- 1 CENTER REVERSING EDGE ON CENTER LINE OF DOOR, WITH CONNECTIONS AT PROPER END.
- 2 STAPLES, OR CARPET TACKS, ARE USED TO HOLD BOTH SIDE TABS IN PLACE.
- 3 STARTING ON CENTER LINE, & WORKING TOWARD BOTH ENDS, ON BOTH SIDES, SPACE TACKS ABOUT 2" APART. AVOID WRINKLING OF TABS.
- 4 IF DECORATIVE STRIPS ARE TO BE USED, USE EXTERIOR GRADE PLYWOOD - 1/4" x 1 1/2". ATTACH THESE STRIPS WITH #6 X 1" WOOD SCREWS, OR DRIVE SCREWS, SPACED ABOUT 8" APART.
- 6 OTHERWISE, ATTACH TABS PERMANENTLY, USING #6 X 1" WOOD, OR DRIVE, SCREWS, SPACED 8" APART, APPROXIMATELY.

"U" SHAPED REVERSING EDGE METHOD "B"

- 1 TEMPORARILY ATTACH THE SPACER STRIP TO THE OUTSIDE FACE OF THE DOOR LEAF.
- 2 CENTER THE REVERSING EDGE ON CENTER LINE OF DOOR WITH CONNECTIONS AT THE PROPER END.
- 3 STAPLES, OR CARPET TACKS, ARE USED TO HOLD THE SIDE TAB IN PLACE.
- 4 TAKE PARTICULAR CARE TO KEEP THE EDGE OF THE TAB EXACTLY EVEN, ALONG ENTIRE LENGTH OF DOOR EDGE.
- 5 EXCESS TENSION ON TABS, AND UNEVEN TENSION, WILL CAUSE TAB TO WRINKLE.
- 6 USE #6 X 1" WOOD SCREWS, OR DRIVE SCREWS, SPACING THEM ABOUT 8" APART.
- 7 REMOVE SPACER STRIP AND CARPET TACKS.
- 8 FOLD REVERSING EDGE TO BOTTOM OF DOOR LEAF.
- 9 STARTING AT THE CENTER LINE, TACK, OR STAPLE, INSIDE TAB IN PLACE, ON 2" CENTERS.
- 10 IF DECORATIVE STRIP IS TO BE USED, USE EXTERIOR GRADE PLYWOOD - 1/4" x 1 1/2". ATTACH THIS STRIP WITH #6 X 1" WOOD SCREWS, OR DRIVE SCREWS, SPACED ABOUT 8" APART.
- 11 OTHERWISE, ATTACH TAB TO INTERIOR FACE OF DOOR LEAF WITH THESE SCREWS, 8" APART.

LEADING EDGE OF ROLLING CURTAIN DOORS :

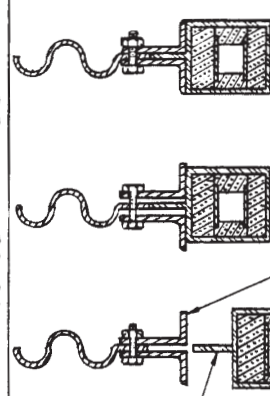

BASE ANGLES OF LEADING EDGE OF ROLLING CURTAIN DOOR.

"T" SHAPED REVERSING EDGE

- 1 LOOSEN FASTENERS OF ANGLES OF LEADING EDGE OF ROLLING CURTAIN DOOR.
- 2 PLACE "T" MOUNTING TAB OF REVERSING EDGE BETWEEN ANGLES.
- 3 TAKE CARE NOT TO GET TAB TOO HIGH & PINCH THE HEAT SEALED PORTION, TO CAUSE PUNCTURE, OR PERMANENT CONTACT OF CONDUCTORS.
- 4 TIGHTEN ANGLES AT ELECTRICAL CONNECTIONS FIRST, THEN OPPOSITE END.
- 5 THEN WORK FROM CENTER, IN BOTH DIRECTIONS.

CUT-AWAY VIEW OF REVERSING EDGE

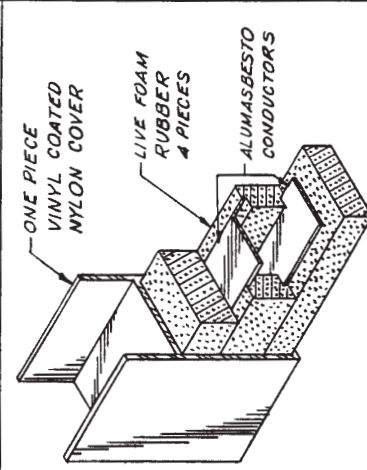

REVERSING EDGE CONSTRUCTION "U" SHAPED CONFIGURATION SHOWN

CONTACT STRIPS ARE ON OPPOSITE FACES OF THE CENTER CHANNEL. AN EVEN, LATERAL PRESSURE ON THE REVERSING EDGE MAKES AN ABSOLUTE CONTACT FOR A STOP AND REVERSING ACTION

SCALE: NONE	APPROVED BY:
DATE: 1-21-80	REVIEWED:
DRAWING INSTRUCTIONS FOR ELECTRICALLY OPERATED REVERSING EDGE	
DRAWING NUMBER: 15400.3	

ASSEMBLY INSTRUCTIONS

1. ASSEMBLE RAIL SPLICES ENDS OF ONE SECTION OF RAIL ASSEMBLIES. ATTACH WITH 3/8" HARDWARE PROVIDED WITH HEADS OF SCREWS ON INSIDE OF RAILS.
2. ATTACH SECOND SECTION OF RAIL ASSEMBLY TO SPLICES. RAIL SECTIONS SHOULD BE END TO END WITH SPLICES AS SHOWN AT LEFT.

RAIL SPLICE
2100-1855, 2 REQ'D

3/8" HARDWARE
ASSEMBLE WITH
BOLT HEADS TO
INSIDE OF RAILS

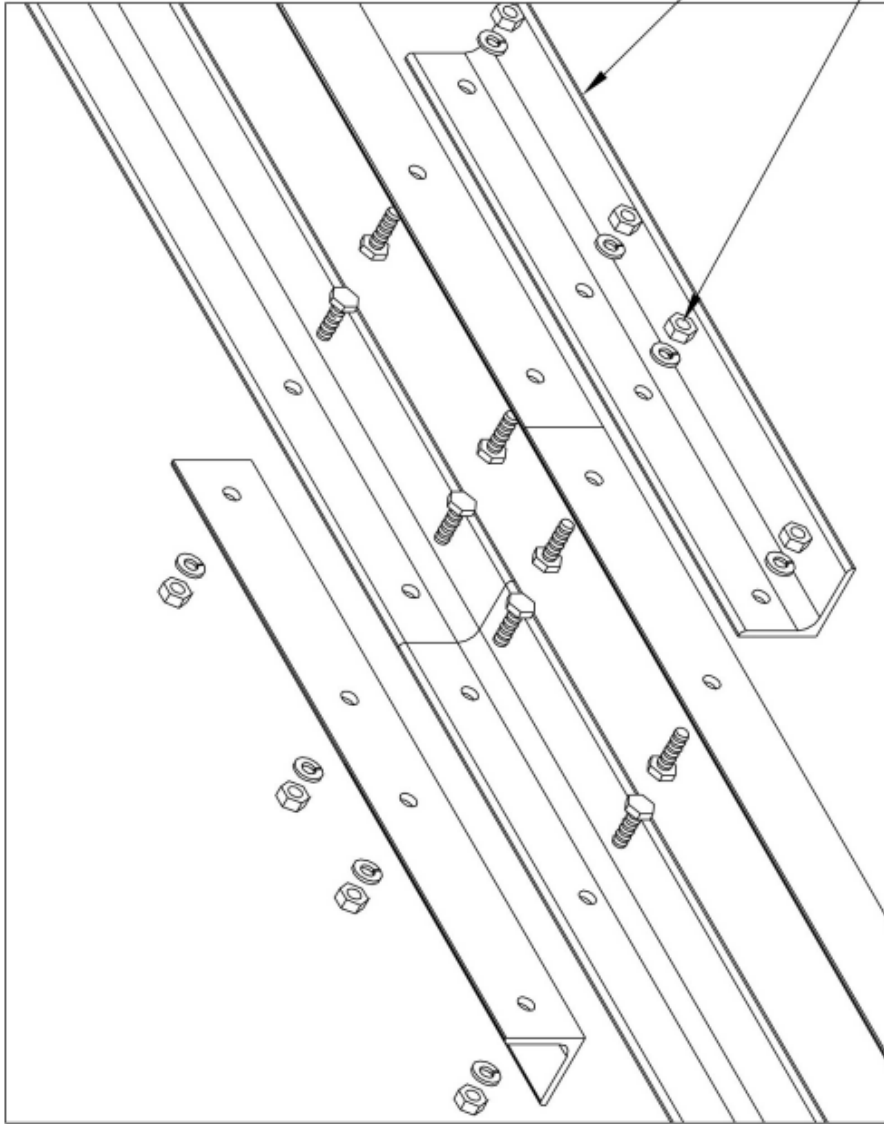

- 3/8" HARDWARE CONSISTS OF:
- 8 2400-016 3/8" LOCKWASHERS
- 8 2400-015 3/8-16 HEXNUTS
- 8 2400-014 3/8-16 X 1" HEX HD SCREWS

UNLESS OTHERWISE SPECIFIED
DIMENSIONS ARE IN INCHES
TOLERANCES: FRACTIONS ± 1/32
ANGLES ± 1°
2 PLACE DECIMALS ± .015
3 PLACE DECIMALS ± .005

CUSTOMER

MATL. PROC.

PROJECT

BY DATE

PR 6/7/02

SIZE FORMER DWG. NO.

A 2700-403

DWG. NO.

2700-403

OF

DF

INSTRUCTIONS FOR ATTACHING RAIL
SPLICES TO MULTI-SECTION RAIL
ASSEMBLIES

REV.

SCALE

SHEET

CHECKED

APPROVED

PREPARED

DATE

BY

NEXT ASSY.