

# H588-6 INSTALLATION

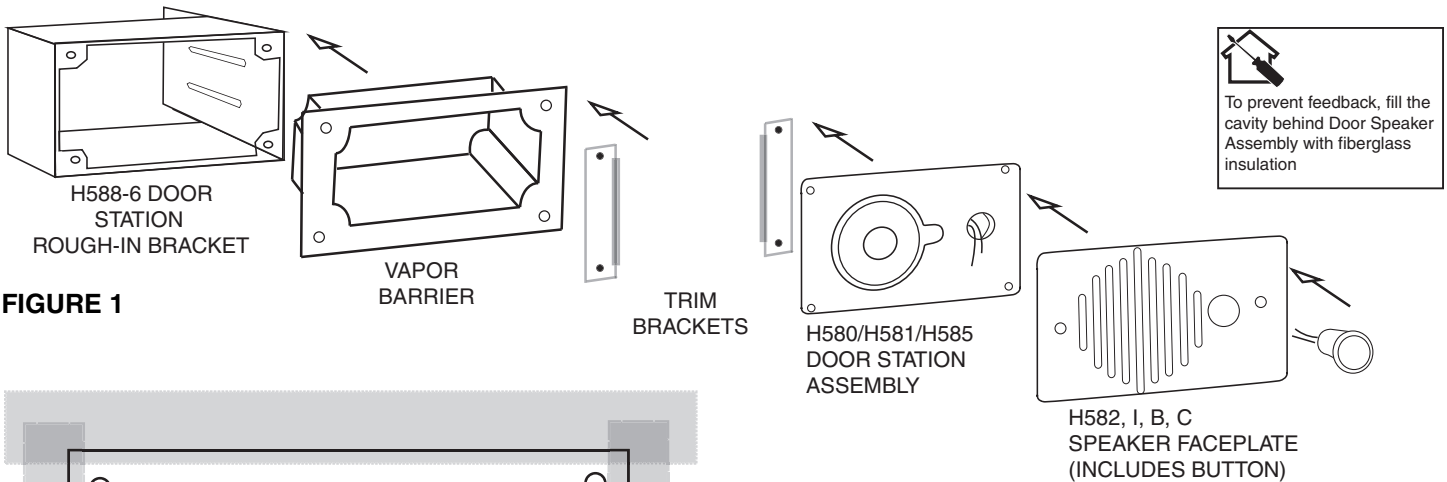

The H588-6 Door Speaker Rough-In Bracket is designed to be installed with a vapor barrier in order to meet building code standards that require moisture proof barriers in outdoor installations. The use of the vapor barrier has the side-effect of prolonging the life of H580, H581 and H585 Door Stations and cameras by reducing moisture (especially in

coastal areas.) The vapor barrier is installed inside the H588-6 Rough-In Bracket, then sealed with fireproof tape or duct tape (see Figure 2.) The door station assembly is then mounted from the front. **Figure 1** shows an exploded view of a properly installed vapor barrier with an H580, H581 or H585. Outside dimensions are shown in **Figure 3**.



**FIGURE 1**

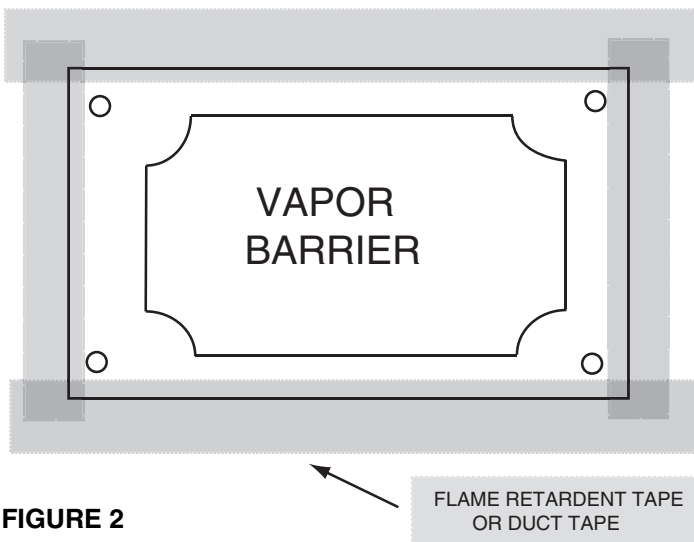

**FIGURE 2**

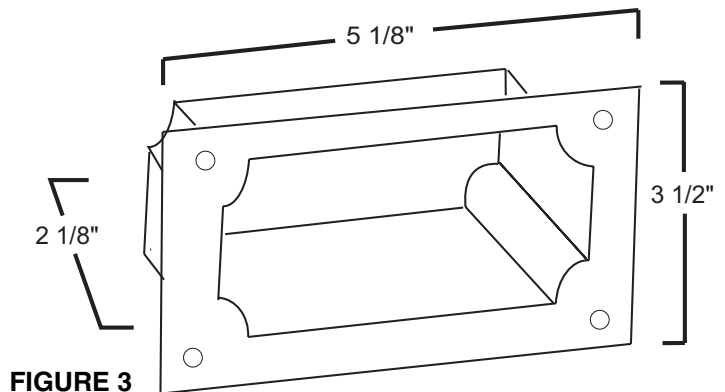

**FIGURE 3**

## Warranty

Linear LLC warrants this product to be free from defects in material and workmanship for two years (2 years). The time period will be measured using the date code labeled on the product. Linear LLC is not responsible for damage to the product resulting from the buyer's improper handling, stocking or warehousing of the product. Any implied warranty arising from the sale of the product including implied warranties of merchantability and fitness for purpose are limited. Linear LLC shall not be responsible for any losses, damages or expenses, whether direct, consequential, or incidental arising from the use or the inability to use the product. Some states and countries do not allow limitations on how long an implied warranty lasts or the exclusion or limitation of incidental or consequential damages, so the above exclusions may not apply. The Linear LLC warranty gives specific legal rights in addition to other rights, which may exist and vary from state to state and country to country.

The warranty is limited to repair or replacement of products returned, freight prepaid, to Linear LLC, there is NO PROVISION FOR LABOR COST OR OTHER REIMBURSEMENTS OF ANY KIND.

1. Failures due to product abuse, such as negligence, improper use, and electrical surge including damage from lightning, water damage or other damage due to natural disasters are not covered by the warranty. The most common form of product abuse is surge damage caused by lightning.
2. The warranty shall also be voided by any tampering with the date code, labels or other markings on the product.
3. Products that are damaged in transit to Linear LLC due to improper packaging or by the carrier (shipping company) will not be covered under the warranty. If the product was damaged or lost by the carrier, it is the sender's responsibility to create a claim against the carrier.
4. The user is responsible for all labor costs associated with removing, reinstalling and returning the product to Linear LLC.

Linear LLC, at its option, will repair or replace the defective product. Replacements will be made from B-Stock, if an exact replacement is not available, Linear LLC, at its option, will select the nearest equivalent product. The user is responsible for freight charges to Linear LLC. Linear LLC will return warranted repaired or replacements by UPS Ground or an equivalent service. A customer may pay the additional costs for second-day or next-day service.

All products returned for warranty service require a Return Product Authorization Number (RPA#). Contact Linear Technical Services at 1-800-999-5225 for an RPA# and other important details.